

POWERHOUSE

XM-580 LOG SPLITTER

Operation Manual



Read the manual thoroughly before use

Thank you for purchasing the XM-580 9-Ton Log Splitter. For your safety and your personnel's safety please read this operation manual carefully and strictly follow all the instructions. This will ensure that you will enjoy a long and satisfactory use of this product.

SPECIAL WARNING WHEN USING THE LOG SPLITTER

Using this powerful Log Splitter may create special hazards. Take extra precautions when using this Log Splitter to safeguard yourself and those around you. Please observe basic safety precautions when operating and maintaining this Log Splitter to avoid injury.

GENERAL SAFETY RULES

The operation of this Log Splitter always carries the possibility of some risk of personal injury to the user. To minimize the possibility of these risks when operating this Log Splitter please follow these basic safety rules:

1. Read and fully understand this operation manual, including the proper use and scope of application as well as potential hazards.
2. Before using this product, check for damaged parts. Inspect the protection device and make sure there are no damaged parts to ensure the Log Splitter can operate normally and perform its intended purpose. Check parts that are intended to move and test if they are moving freely and do not appear to be broken or cracked. Note any other conditions that may have a negative effect on the operation of the Log Splitter and have them checked by an authorized professional if needed. You must make sure to have defective or damaged parts replaced and have the Log Splitter repaired if it is not operating properly before actual use and operation.
3. Before doing any inspection, calibration or other maintenance work on the Log Splitter make sure that the Log Splitter is unplugged. Do this even when simply changing spare parts such as wedge, chisel or cutting bar.
4. Keep the protective device in the state of readiness for work at all times.
5. Always check and make sure that the cord is intact and fully protected.
6. Do not open the switch box or the electrical motor cover of the Log Splitter. Contact an authorized professional to do this if necessary.
7. Make sure the Log Splitter and cord are kept away from water and any moisture.
8. Handle the cord with proper care. Never yank or tear out the power cord. Keep the cord away from high temperature, oil and sharp objects.

ELECTRICAL SAFETY

1. Before connecting the power cord to a power source, make sure the Log Splitter's Electrical Motor Switch is off.
2. Connect the power cord to a standard, properly grounded, power source that supplies power that meets specifications stated on the Log Splitter nameplate and protected by a 16 Amp circuit breaker.
3. Do not operate the Log Splitter if there is an electrical hazard.
4. Do not operate the Log Splitter in wet conditions.
5. Do not operate the Log Splitter with an improper electrical cord.
6. Do not make electrical repairs by yourself.
7. If in doubt, always consult a qualified and authorized electrician.

Using a Power Extension Cord

If it is necessary to use a power extension cord:

1. We recommend one that is moisture-proof. Moisture can produce a voltage drop, which can impede the electrical motor from gaining full power and reduce the Log Splitter's performance.
2. Use only power extension cords that are 10 meters or less in length and 2.5 square millimeters or more in diameter. Do not use power extension cords longer than 10 meters in length or thinner than 2.5 square millimeters in diameter.

HYDRAULIC SYSTEM SAFETY

Always check for hydraulic leaks before using the Log Splitter. Spilled hydraulic fluid can cause accidents such as slips and falls. Hydraulic oil on your hands can also cause your hands to slip while operating the Log Splitter. Spilled hydraulic oil can also cause a fire. Be sure the Log Splitter and your work area are clean and free of oil spills.

Never operate the Log Splitter if the hydraulic system is not working properly. This may cause damage to your Log Splitter and may be hazardous to the operator.

PHYSICAL SAFETY

Operating the log splitter presents some possible physical hazards which can be minimized by doing the following:

1. Always wear the proper safety gloves, safety hard-toed shoes, and the approved eye protection gear when operating the Log Splitter.
2. Never operate the Log Splitter while under the influence of drugs, alcohol and certain medication.
3. Never stay on top of the Log Splitter. You risk bodily injury if you fall.
4. Clean up as you work; accumulated split wood and wood chips can create a hazardous work environment.
5. Always check the Log Splitter for lodged splinters to avoid possible puncture injury or potential jamming of the Log Splitter.
6. Do not work in a cluttered work area, which may cause you to slip, trip or fall.
7. Keep onlookers away from the Log Splitter, and do not allow unauthorized persons to operate the Log Splitter.
8. Always keep a safe distance between your hands and the log, and between the pusher and the wedge. When the splitter is turned on, do not put your hand on any moving parts of the Log Splitter.
9. Remove all jewelry and ornaments, and never wear loose clothes when operating the Log Splitter. These can get entangled with the log chips which may cause injury.

FEATURES OF THIS LOG SPLITTER

1. Portable – It is small and lightweight with built-in wheels making it easier to move around any work area.
2. Powerful – Its 30cm hydraulic ram delivers 9-tons of power making all your log splitting tasks quick and easy.
3. Electric Powered – It has a reliable, electric powered, hydraulic system that eliminates the expenses and hassle of maintaining a small gas engine. Just plug it in and start splitting logs.

4. Hydraulic Ram – The powerful hydraulic ram splits logs in a safe, controlled manner, without the need for axes, sledge hammers or wedges.
5. Two-Hand Safety Control – Its built-in safety design keeps your hands away from the log and splinter during operation.
6. Durable Steel Construction – With its welded steel construction and enclosed design you get a tough and durable log splitter you can depend on for many years.

MAIN SPECIFICATIONS

XM-580

Electrical motor:	110-120 volts/60 hertz/2850 rpm 110-120v, 19.5amp, 60hz
Max. force:	9 Tons
Log size capacity:	520 mm (length) (50 - 300) mm (diameter)
Ram Travel:	300 mm
Ram Diameter:	30 mm
Hydraulic Oil Capacity:	3.1 liters
Overall dimensions:	1070 mm (length) x 300 mm (Width) x 490 mm (height)
Net Weight:	49 kgs

OPERATING SAFETY RULES

- Only adults that have read this operation manual are allowed to operate the Log Splitter.
- This Log Splitter must be operated by only one person at a time.
- Do not split logs bigger than the specified log size capacity or logs too small to fit the Log Splitter properly.
- Do not split green logs. Green logs may jam frequently due to moisture content.
- Remove all foreign objects from the logs, which may jam or damage the Log Splitter, such as nails, screws, and wires before splitting.
- Remove all branches from the logs before splitting.
- The log end surface must be level when placed on the Log Splitter.
- Always split logs along the direction of vein.
- Do not put logs vertically on the Log Splitter. This may damage the Log Splitter.
- Always use both hands to handle the control device. Do not use other means to operate the control device.
- Always Position the Log Splitter on a surface 60-75cm high. The surface must be free from any objects for complete freedom of movement for the operator while working. We recommend using a special Log Splitter platform.
- Do not operate the Log Splitter from the ground. This increases the risk of injury due to splinters or chips and makes the operation difficult.
- Split only one log at a time. Do not split 2 logs at a time as the log may jump up and cause an accident.
- Do not put or change logs while the Log Splitter is running.
- When operating the Log Splitter make sure other people and animals are at least 5 meters away from the Log Splitter.
- Do not tamper with the protective device of the Log Splitter. Also do not operate the Log Splitter without the protective device.
- Do not force a log for more than 5 seconds on the Log Splitter. This may cause damage to the Log Splitter. In case this happens, stop the Log Splitter then turn the log 90 degrees.

- Try splitting the log again. If the log still does not split, it means the hardness of the log is higher than the maximum power capacity of the Log Splitter. Continuing to force the log may just damage the Log Splitter.
- Do not leave the Log Splitter running unattended. If you need to move away from the Log Splitter, turn it off first and just turn it back on when you return. When done using it, turn the Log Splitter off and unplug the power cord.
- Do not operate the Log Splitter near any flammable materials such as natural gas tanks or fuel cans.

Recommended Log Size Capacity

The recommended log dimensions for the Log Splitter are 520 mm (length) × (50 - 300) mm (diameter). The specified diameters are more for reference. What is more important is the hardness of the log and the Log Splitters capability to split it. Hard logs with knots may be too difficult for the Log Splitter to split.

UNPACKING AND CHECKING BEFORE INSTALLATION

Before installing and using the Log Splitter, remove all the components from the packaging and check if they are complete and in good condition. Sort and check all the components for damages. If there are any damaged or missing components, please report it immediately to your dealer.

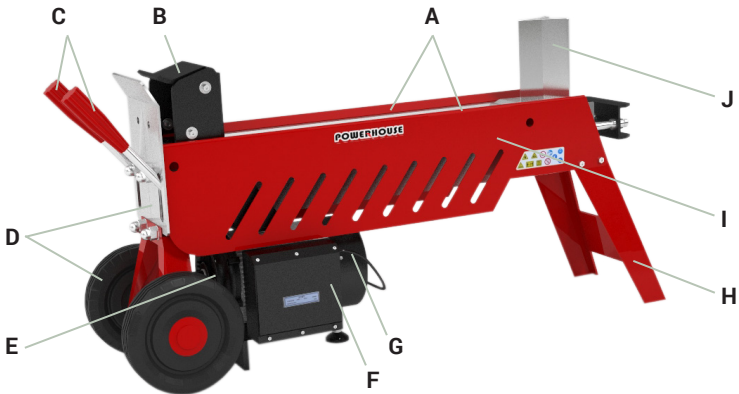

Figure 1 List of major components

Check the components based on the following list in Figure 1.

- | | |
|-----------------------------|-----------------------------|
| A Log guiding plates | F Electrical motor switch |
| B Log pusher | G Electrical motor assembly |
| C Operating handle assembly | H Supporting feet |
| D Wheel and frame | I Main Body |
| E Oil pump | J Splitting wedge |

All the necessary screws, bolts, washers and jigs are in a separate box. (See attached parts list).

INSTALLING THE LOG SPLITTER

Installing the Wheels and Supporting Feet

1. Carefully unpack the Main Body of the Log Splitter from the box and, with the help of another person, place it on the foam material included with the box. (See Figure 2)

2. Place the supporting feet (C in Figure 2) and attach to the Main Body (B in Figure 2). Attach using 2 screws (21) and 2 nuts (20) then tighten. (See Figure 3)

3. While the Main Body is still supported on the foam block, attach safety rings (59) and the 2 wheels (60) to the shaft of the wheel frame (61), then use the wheel shaft cover (58) to cover the wheels.

4. Make sure that the wheels are able to turn freely and uniformly. (See Figure 3).

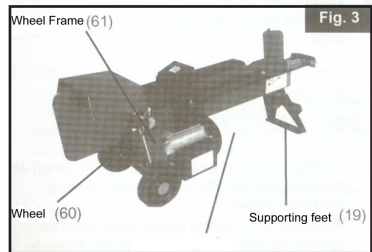
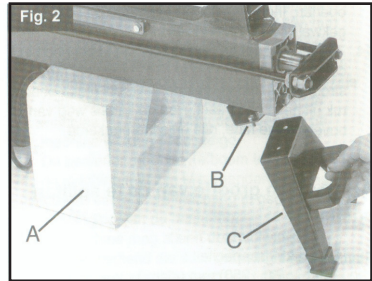

Installing the Operating Handle

Unpack the operating handles (54/55) from the box and screw them in the receiving hole (52) of the handles on the Main Body, then turn the handles to tighten. (See Figure 4).

The Log Splitter is now assembled and ready for use.

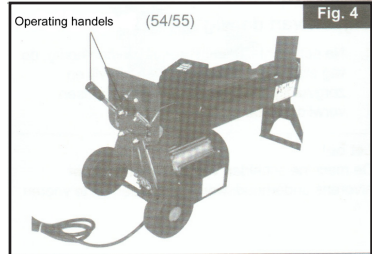

OPERATING PROCEDURE

1. **Prepare Work Area** – Make it safe and efficient by planning the work before you begin. Position your logs for splitting within easy access. Prepare an area where you will place the split logs also within easy reach. If they will be loaded into a receptacle or on a truck, position as near as possible.

2. **Prepare Logs for Splitting** – Sort out your logs before you start splitting. Separate logs you can split from the logs you cannot, logs that are too long, too small, and too green. Check out Operating Safety Rules for more details. Remove any foreign material that may obstruct the Log Splitter operation such as nails, wires, or screws. These may also get flung during splitting and cause an accident. Remove any branches from the log as well.

3. **Setup Power Source** – Locate a power outlet that meets the required power requirements. Connect the Log Splitters power cord to the power outlet and make sure it is secure. If the Log Splitter is too far for the power cord to reach the power outlet, use a power extension cord that meets the required power load to connect the Log Splitter to the power

outlet. Make sure that the cord is laid out securely and safely to avoid people tripping on it and to avoid damage to the cord itself. Also make sure that the cord is laid out far from wet and moist areas.

4. Position Log Splitter Securely – place the Log Splitter firmly on a level, solid table or platform, 60-70cm high. Make sure there are no objects around the tabletop where the Log Splitter will be placed. This is to ensure that the operator has complete freedom of movement while working. Do not operate the Log Splitter while it is on the ground. This may cause injury due to splinters or chips and may also make the operation difficult. It is recommended that you setup the Log Splitter on a special Log Splitter platform. For additional support, you may also block the wheels from moving by putting wedges which will prevent them from rolling.

5. Open the Air Bleed (A in Figure 5) – Loosen the Bleed Screw (14) by turning it 3-4 times every time before using the splitter. Re-tighten the bleed screw every time after you have finished using the Log Splitter.

6. Place Log on the Splitter. Put a log lengthwise on the Main Body of the splitter (I in Figure 1). It should be flat on the Splitter cradled between the Log Guiding Plates (A in Figure 1). Do not split a log at an angle. Make sure that one end of the log is squarely in contact with the Wedge (J in Figure 1) and the other end with the Log Pusher (B in Figure 1).

7. Start Splitting Logs – Press down on the Electric Motor Start Switch (F in Figure 1) with one hand. The motor will start to spin. Wait a few seconds until the motor spins fast enough to create the necessary pressure in the Hydraulic pump. When there is enough pressure, depress the Operating Handle with your other free hand (C in Figure 1). This will move the Log Pusher (B in Figure 1) in the direction of the log and compress the log against the Wedge (J in Figure 1). This motion will instantly split the log. As soon as the log is split, release the Electric Motor Start Switch (F in Figure 1) with one hand and the Operating Handle (C in Figure 1) with the other hand. This will make the Log Pusher (B in Figure 1) retract to its original position.

Warning! A log should split in less than 5 seconds when run through the Log Splitter. If during the process a log does not split immediately, do not force it. See the next section on how to split hard logs.

8. Stack Them All Up – assign an area for the logs for splitting, the logs too hard for splitting and the logs already split. Stack them up in their respective areas. This will keep your work area uncluttered and safe.

9. Shutting Down After Use – After using the Log Splitter, remember to re-tighten the Bleed Screw (Pos. 14 in Figure 5). Always unplug the power cord after each use.

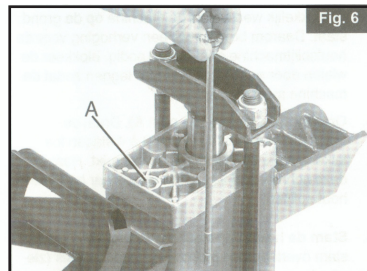
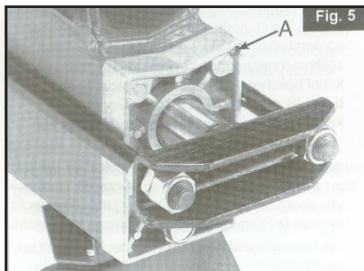

HOW TO SPLIT A HARD LOG

In case a log does not split within 5 seconds:

1. Stop the Log Splitter then turn the log 90 degrees.
2. Try splitting the log again.
3. If the log still does not split, it means the hardness of the log is higher than the maximum power capacity of the Log Splitter. It is better to just set the log aside.

HOW TO FREE A JAMMED LOG

In case a log gets jammed in the Log Splitter:

1. Release the Electric Motor Start Switch and the Operating Handle. This will fully retract the Log Pusher.
2. Get a triangular wedge of wood and insert it under the jammed log.
3. Re-start the Log Pusher to push the wedge under the jammed log.
4. Repeat the process several times using a larger piece of triangular wedge of wood every time until the jammed log is free.
5. Do not use a hammer to free a jammed log.
6. Do not hold the jammed log or place your hands near the jammed log when trying to free it.

HOW TO USE THE OPERATING HANDLE

- When the Operating Handle is in the first setting or positioned in the middle, the Log Pusher moves faster but with less power.
- When the Operating Handle is fully depressed or positioned towards the bottom, the Log Pusher moves slower but with maximum power.

MAINTAINING THE LOG SPLITTER

Warning!

Be sure to unplug the power cord before doing any maintenance work!

Sharpening the Wedge

There is usually no need to sharpen the wedge until after long periods of operation. When it is required, use a fine-toothed file to sharpen the Wedge. Carefully remove any flat spots or burrs on the edge.

Changing the Hydraulic Oil

1. Check that the Log Pusher (B in Figure 1) is fully retracted to its original position.
2. Tilt the Log Splitter to position the Oil Fill/Drain Port (in Figure 7) pointing up.
3. Unscrew and remove the Dip Stick (10) together with the O-type oil seal (11). (Figure 6).
4. Place an empty container that can hold at least 4 liters of oil under the Log Splitter.
5. Tilt the Log Splitter to let the oil spill into the container until all the oil is emptied into the container.
6. Tilt the Log Splitter the other way, to position the Oil Fill/Drain Port (in Figure 7) up again.
7. Pour the specified volume of Hydraulic Oil into the hydraulic oil cylinder using a clean funnel. Use only the recommended hydraulic oil specifically made for this purpose. (see Recommended Hydraulic Oil in next section)
8. Clean the Dip Stick (10), and re-insert it fully to check the oil level. It should be between the two marks on the dipstick.

9. Clean and re-install the O-Type SEAL (11) and the Dip Stick (10). Do not damage the threads of the aluminum Oil Cylinder Cover when re-installing.

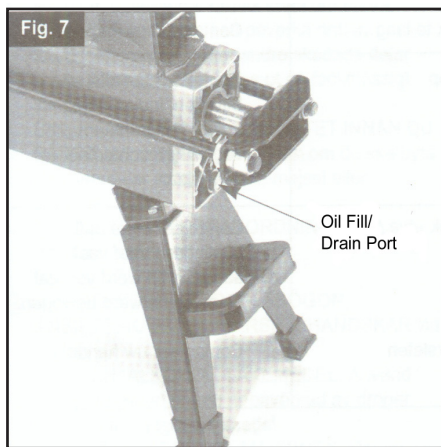

Reminder!

Dispose used dirty oil properly. Take it to a waste oil-recycling center. Do not dump it in the sewer or on the ground or mix in with the trash.

Recommended hydraulic oil

The following are the recommended hydraulic oil brands to be used for the hydraulic ram of the Log Splitter.

1. SHELL TELLUS T22
2. ARAL VITAM Gf22
3. P ENGERGOL HCP22
4. MOBIL DTE11

(Do not use other brands of hydraulic oil)

Trouble-shooting

Here are the most common problems that may occur when using the log splitter and their corresponding recommended solutions. In case there are problems that cannot be resolved please contact your dealer. Have an authorized professional check and carry out maintenance and repairs if needed. If the Log Splitter has been operated on by any unauthorized personnel, the guarantee for the Log Splitter will automatically be null and void and the manufacturer will be relieved of any responsibility for any injury to persons and animals and any damage to property.

Problem	Probable cause	Corrective action
Log does not split	<ul style="list-style-type: none"> • Log is positioned incorrectly • Log exceeds permitted dimensions or the wood is too hard for the capacity of the Log Splitter. • Wedge does not cut • There is an oil leak • Hydraulic pressure too low 	<ul style="list-style-type: none"> • Re-position the log. • Make sure it is not at an angle. • Stop the Log Splitter then turn the log 90 degrees then try splitting the log again. • Try to cut a small part or use other means to reduce the size of the log • Sharpen the wedge, check for burrs or nicks, file if necessary. • Locate the leak using a piece of card or wood. Contact your dealer. • Check oil level. Fill oil if necessary. If problem persists, contact your dealer.
Log Pusher/Cam advances jerkily or with strong upward vibrations	<ul style="list-style-type: none"> • There is air in the circuit • Leakage from the tank 	<ul style="list-style-type: none"> • Make sure the bleed screw is unscrewed.
Oil leak from the Cams or from other external points	<ul style="list-style-type: none"> • Seals worn 	<ul style="list-style-type: none"> • Contact your dealer

Parts Diagram

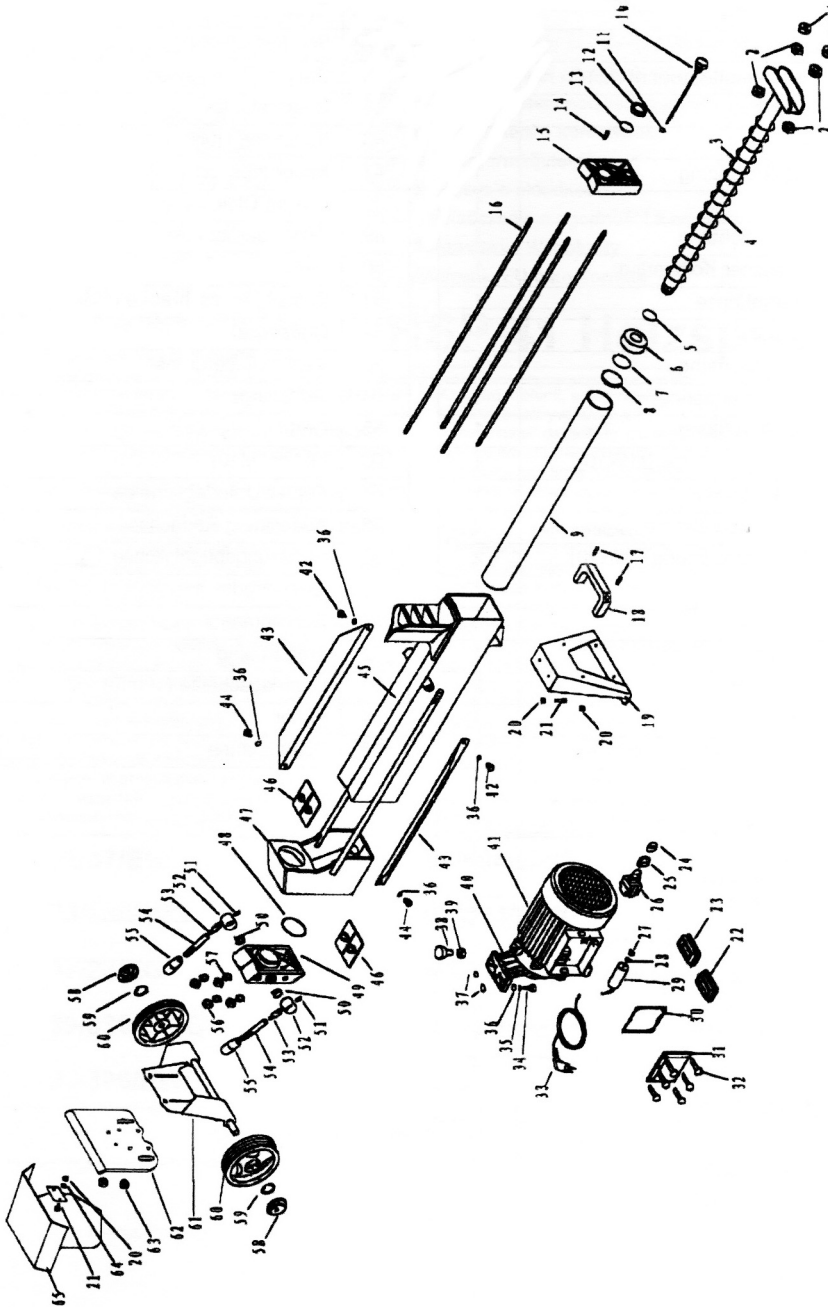

Model XM-580 Log Splitter Parts List

No	Name	Qty
1	Hexagonal nut (M14)	2
2	Hexagonal nut thin (M14)	4
3	Hammer ram	1
4	Spring	1
5	O-ring oil seal	1
6	Piston	1
7	O-ring oil seal	1
8	Square piston ring	1
9	Oil cylinder casing	1
10	Dip stick	1
11	O-ring oil seal	1
12	Teflon seal ring	1
13	O-ring oil seal	1
14	Bleed screw (M3x10)	1
15	Oil cylinder cover	1
16	Screw stud	2
17	Philips screw (M6x20)	2
18	Carrying handle	1
19	Supporting foot	1
20	Nut (M6)	4
21	Screw (M6x14)	2
22/23	Rubber supporter for electrical motor	1
24	Switch dust shield	1
25	Switch	1
26	Switch seat	1
27	Nut (M8)	1
28	Fixing washer	1
29	Capacitor	1
30	Dustproof rubber sealing ring	1
31	Capacitor casing	1
32	Philips screw	8
33	Cord and plug	1
34	Screw (M8x30)	3

No	Name	Qty
35	Ring spring (8 mm)	9
36	Washer (8 mm)	13
37	O-ring oil seal	2
38	Screw (8 mm)	1
39	Nut (M8)	1
40	Oil pump cover	1
41	Electrical motor assembly	1
42/44	Screw (M8x30)	4
43	Log guiding plate	2
45	Main Body	1
46	Plastic sheath plate	2
47	Log pusher assembly	1
48	O-ring oil seal	1
49	Oil cylinder cover - front	1
50	Spring	1
51	Fixing screw (M8x30)	1
52	Handle seat	1
53	Valve knob	1
54	Handle bar	1
55	Handle	1
56	Nut M8	2
57	Brass shim	4
58	Wheel axle cover	2
59	Shaft fixation hook	2
60	Rubber wheel	2
61	Wheel frame	1
62	Support plate	1
63	Washer (10 mm)	2
64	Spring	1
65	Protection hood	1

Symbols used

Standard graphic symbols are used on all Log Splitters for uniform and accurate understanding of information. This ensures total safety and protection for the users and the Log Splitter Log Splitter. As these symbols are very important, pay close attention to the information below.



Read the Log Splitter's operation and maintenance manual in full before using your Log Splitter.



Always wear safety footwear when operating the Log Splitter. This will provide protection against possible injury from logs accidentally falling on feet.



Always wear gloves when operating the Log Splitter. This will protect the hands against chips and splinters, which may be generated during operation.



Always wear goggles/visor when operating the Log Splitter. This protects the eyes and face from chips and splinters, which may be generated during operation.



Do not remove or tamper with the protection and safety devices on the Log Splitter.



Only the person operating the Log Splitter should be within 5 meters of the Log Splitter when in use. No other person or animal may be present within the 5 meter radius.



Any used oil for disposal from the Log Splitter must not be dumped into the environment. The disposal of such bi-products must be done in accordance with current laws in the country where this Log Splitter is used.



Hand hazard area. Do not touch while the wedge is operating as it may cut or crush your hands.



Warning! Always pay attention to the movement of the log pusher when operating the Log Splitter



Warning! Do not remove a log trapped in the wedge with your hands.



Warning! Always disconnect the power cord before conducting any inspection or maintenance operation on the Log Splitter.

Warning! Use only voltage indicated on the rating plate

Please Read the Following Carefully

The parts diagram in this manual has been provided by the manufacturer and/or distributor, only as a reference tool. The manufacturer or distributor does not make any representation or warranty to the buyer that he or she is qualified to make any repairs to, or replace any parts of the product. The manufacturer and/or distributor expressly states that any and all repairs and replacements of parts must be done by certified and licensed technicians and not by the buyer. If the buyer chooses to undertake his or her own repairs or replacement of parts to the original product, the buyer assumes all risk and liability arising from his or her repairs and/or replacement parts.

WARRANTY

Limited Warranty for the Powerhouse XM-580

What is covered

Your Log Splitter is warranted against original defects in material and workmanship for a period of one (1) year from the date of purchase, when used for purposes in accordance with this User's Guide. This warranty provides for the repair or replacement of the unit. Replacement product or parts may include re-manufactured or refurbished parts or components.

Effectivity

The one (1) year warranty for all parts and labor applies to the date of first purchase. This is valid only for the first purchaser.

What is not covered

- Units purchased from unauthorized dealers.
- Units with defaced, modified, or removed serial numbers.
- Damage, deterioration, or malfunction due to:
 - a. Accident, misuse, neglect, fire, water, lightning, or other acts of nature.
 - b. Unauthorized modification of unit.
 - c. External sources such as power fluctuation and weather.
 - d. Repair or attempted repair and alteration by unauthorized parties.
 - e. Any damage to product due to shipment.
 - f. Removal or installation of product.
 - g. Use of parts and supplies other than those produced or recommended by Powerhouse Log Splitters.
- Removal, installation, and set-up service charges.

Warranty Service

- Contact Powerhouse. the helpline for more information regarding obtaining warranty service 503.575.9407.
- To obtain warranty service, be ready to provide the following: serial number, date and place of purchase, original dated sales slip, your name and address, and a description of the problem.
- All repair work will be done by Powerhouse or its authorized agents.
- Any replaced defective parts will not extend this warranty period.
- Service under warranty will not extend this warranty period.

Warranty Limitations and Exclusions

- There are no warranties, express or implied, which extend beyond the description contained herein including the implied warranty of merchantability and fitness for a particular purpose.
- Powerhouse' liability is limited to the cost of repair or replacement of the product. Powerhouse', Inc. will not be liable for any consequential damages or incidental damages you incur in connection with your purchase and use of your unit. This limitation is not allowed by some states and so this limitation may not apply to you.
- This warranty gives you specific legal right. You may also have other rights that vary by state.

Sales outside the U.S.A.

For Powerhouse' products sold outside the U.S.A, contact your dealer for warranty information and service.

POWERHOUSE
XM-580 LOG SPLITTER