



**DUAL ACTION
13 / 16 TON
GAS LOG SPLITTER**



**MODEL NO.
GD13T21 / GD16T21
Owner's Manual**

ASSEMBLY & OPERATING INSTRUCTIONS

Purchase Date _____ Model NO. _____ Serial NO. _____
Dealer _____

Boss Industrial, Inc. · 123 Ambassador Drive, Suite 123 · Naperville, IL 60540 · USA
Phone: (800) 780-BOSS (2677) · Fax (331) 472-2976

To The Owner

Thank You!

Thank you for purchasing a BOSS Log Splitter. It was carefully engineered to provide excellent performance when properly operated and maintained.

Please read this entire manual prior to operating the equipment. It instructs you how to safely and easily set up, operate and maintain your machine. Please be sure that you, and any other persons who will operate the machine, carefully follow the recommended safety practices at all times. Failure to do so could result in personal injury or property damage.

All information in this manual is relative to the most recent product information available at the time of printing. Review this manual frequently to familiarize yourself with the machine, its features and operation. Please be aware that this Operator's Manual may cover a range of product specifications for various models. Characteristics and features discussed and/or illustrated in this manual may not be applicable to all models. We reserve the right to change product specifications, designs and equipment without notice and without incurring obligation.

If applicable, the power testing information used to establish the power rating of the engine equipped on this machine can be found at the engine manufacturer's manual or website. If you have any problems or questions concerning the machine, phone an authorized service dealer or contact us directly. Boss Industrial's customer support phone number, website and mailing address can be found on this page. We want to ensure your complete satisfaction at all times.

Throughout this manual, all references to right and left side of the machine are observed from the operating position. The engine manufacturer is responsible for all engine-related issues with regards to performance, power-rating, specifications, warranty and service. Please refer to the engine manufacturer's Owner's/Operator's Manual, packed separately with your machine, for more information.

Customer Support

Please do NOT return the machine to the retailer or dealer without first contacting the Customer Support Department.

If you have difficulty assembling this product or have any questions regarding the controls, operation, or maintenance of this machine, you can seek help from the experts. Choose from the options below:

- ◇ Visit us on the web at www.boss-industrial.com
- ◇ Call a Customer Support Representative at (800) 780-2677 or (331) 457-5670
- ◇ Write to Boss Industrial, Inc., 123 Ambassador Drive, Suite 123, Naperville, IL 60540

Table of Contents

	Page(s)
Important Safety Information.....	1-10
General Safety Alert Signals	1
Safety Decals	2
Safety Symbols	3
Training	4
Pre-operation	5
Operation	6
Operator Zone.....	7
Maintenance Safety.....	8
Fire Prevention	9
Towing Safety	10
Assembly & Set-up Instructions	11-22
Unpacking the Container.....	11-12
Assembling	13-18
Set-up	19-20
Operating Instructions	21-23
Starting & Stopping the Engine.....	21
Using Control Handle.....	21
Splitting the Wood	22
Transporting the Log Splitter	23
Maintenance & Adjustments.....	24-25
Troubleshooting.....	26
Specifications	27
Exploded Diagram & Parts List	28-30
Packing List.....	31
Warranty Service Information.....	32



IMPORTANT SAFETY INFORMATION



WARNING: Read and thoroughly understand all instructions in this manual and on safety decals before assembling or operating this log splitter. Failure to do so may cause serious injury or death. Do not allow anyone to operate this log splitter who has not read this manual. As with all power equipment, a log splitter can be dangerous if assembled or used improperly. Do not operate this log splitter if you have any questions concerning safe operation. To get answers to any questions, call our customer service department at 1-800-780-2677.

Si no entiende ingles, se prefiere que busque alguien que interprete las instrucciones para usted.



This SAFETY ALERT SYMBOL identifies important safety messages in this manual. Failure to follow this important safety information may result in serious injury or death.

CALIFORNIA PROPOSITION 65



WARNING! Engine Exhaust, some of its constituents, and certain vehicle components contain or emit chemicals known to State of California to cause cancer and birth defects or other reproductive harm.



DANGER! This machine was built to be operated according to the safe operation practices in this manual. As with any type of power equipment, carelessness or error on the part of the operator can result in serious injury. This machine is capable of amputating hands and feet and throwing debris. Failure to observe the following safety instructions could result in serious injury or death.

The following signal words and meanings are intended to explain the levels of risk associated with this product.



DANGER

DANGER indicates a hazardous situation which, if not followed, will result in serious injury or death.



WARNING

WARNING indicates a hazardous situation which, if not avoided, could result in serious injury or death.



CAUTION

CAUTION indicates a hazardous situation which, if not avoided, could result in minor or moderate injury.

NOTICE

NOTICE is important information about the proper use of your machine. Failure to follow this instruction could result in damage to your machine or property.



IMPORTANT SAFETY INFORMATION

SAFETY DECALS

Make sure that all safety warning decals are in good condition and readable. Always replace missing or defaced decals. Contact BOSS at 1-800-780-2677 for replacement decals.

CAUTION!

- Read and understand safety and operating instructions in owner's manual completely. Failure to do so may result in serious injury or death.
- Always wear safety glasses, safety shoes, protective hearing devices, and tight fitting gloves during operation.
- Set up log splitter on clear, level, dry and solid ground. Keep off slopes and slippery surfaces. Always block the wheels.
- Do not leave the engine running unattended.
- Only split wood in the direction of the grain.
- No one under the age of 18 should operate log splitter.
- Always stay in operator zone specified by manufacturer during operation.
- Do not stand on or reach over log splitter.

OPERATING INSTRUCTIONS

3 POSITIONS OF CONTROL HANDLE

FORWARD NEUTRAL REVERSE

WARNING!

- Only one person is permitted to load logs and operate controls. Keep bystanders, children, pets and helpers at least 25 ft. away.
- Keep work area clear of split wood, debris, and other obstacles.
- Do not operate log splitter under the influence of alcohol or drugs.
- Keep hands, feet and all body parts away from splitting wedge, end plate, partially split wood, and moving parts.
- Never check for leaks with your hands during operation. High pressure fluid can escape from small holes and cause serious injury by puncturing skin which could result in blood poisoning.
- NEVER use your hands to dislodge a log from the wedge.

WARNING!

- Do not refill hydraulic oil while engine are hot or running.
- Do not refuel a hot or running engine. Allow the engine to cool at least 10 minutes before refueling.
- Never run an engine indoors or in a poorly ventilated area. Engine exhaust contains carbon monoxide, an odorless and deadly gas.
- Engine parts, especially the muffler, become extremely hot during operation. Do not touch.

Part #: 410-175

WARNING!

To minimize risk of serious injury or death to you or others, when towing this log splitter:

- Read instruction manual for how to properly attach coupler to hitch ball and how to tow safely.
- Never attempt to move this machine over uneven or hilly terrain without a tow vehicle or adequate help
- Use the ball of correct size.
- Do not exceed weight capacity of ball or load limits of coupler.
- Always use safety chains.
- Never exceed 45 mph.
- Avoid sharp turns and steep angles.
- Make sure of the coupler tightness each time before towing and after towing 50 miles.
- Replace damaged ball or coupler immediately.

Part #: 410-249

KEEP HANDS / FEET AWAY!

DANGER!

- Do not use your hands to dislodge log from wedge.
- Keep hands away from wedge, end plate, partially slit wood and moving parts.
- If wedge moves FORWARD when control handle released, STOP USE IMMEDIATELY! Valve may be damaged.

Part #: 410-233

DANGER!

KEEP HANDS / FEET AWAY!

- Do not use your hands to dislodge log from wedge.
- Keep hands away from wedge, end plate, partially slit wood and moving parts.
- If wedge moves FORWARD when control handle released, STOP USE IMMEDIATELY! Valve may be damaged.

Part #: 410-235

NOTICE

DIPSTICK

- Maintain oil level within the range specified on dipstick. Check before each use when oil is cold. DO NOT OVERFILL! Never run the log splitter without sufficient oil. The hydraulic pump could be ruined.
- Change hydraulic oil every 100 hours of use. AW32 universal Hydraulic oil is recommended. Dextron II transmission fluid can be used as a substitute should AW32 oil not be available. Do NOT mix AW32 hydraulic oil with Dextron II transmission fluid. Drain the reservoir if you wish to use Dextron II.
- Use only the filter of original equipment manufacturer's (O.E.M.).

Part #: 410-647

BOSS INDUSTRIAL 13 Ton Log Splitter
GD13T21

Max. splitting force: 13 Ton
Max. splitting length: 21 inch
Max. splitting diameter: 13.5 inch
Net weight: 315 lbs
Serial NO.:

Meets ANSI B71.7-1985 Safety Standard

Boss Industrial, Inc.
123 Ambassador Drive, Suite123, Naperville, IL 60540
www.boss-industrial.com, 1-800-780-2677

Part #: 410-512

BOSS INDUSTRIAL 16 Ton Log Splitter
GD16T21

Max. splitting force: 16 Ton
Max. splitting length: 21 inch
Max. splitting diameter: 13.5 inch
Net weight: 342 lbs
Serial NO.:

Meets ANSI B71.7-1985 Safety Standard

Boss Industrial, Inc.
123 Ambassador Drive, Suite123, Naperville, IL 60540
www.boss-industrial.com, 1-800-780-2677

Part #: 410-514

Part #: 410-647

Part #: 410-514



IMPORTANT SAFETY INFORMATION

SAFETY SYMBOLS

This page depicts and describes safety symbols that may appear on this product. Read, understand, and follow all instructions on the machine before attempting to assemble and operate.

Symbol	Description
	READ THE OPERATOR'S MANUAL(S) Read, understand, and follow all instructions in the manual(s) before attempting to assemble and operate.
	FACE PROTECTION Always wear safety goggles or safety glasses with side shields, earplugs and a face shield when operating this product.
	WARNING— MOVING WEDGE Keep hands away from wedge, moving part, end plate, and partially split wood.
	BYSTANDERS Keep bystanders, helpers and children at least 25 feet away.
	SINGLE OPERATOR Only one person should operate the machine at a time. The adult who loads and stabilizes the log must be the person who operates control handle.
	WARNING— PRESSURIZED FLUID Never check for hose leaks with your hands. High pressure fluid can escape through a pin hole leak and cause serious injury by puncturing the skin and causing blood poisoning.
	WEAR GLOVES Always wear nonslip, heavy-duty protective gloves when operating this product.
	WEAR SAFETY FOOTWEAR Always wear nonslip steel-toed safety footwear when operating this product.
	WARNING—GASOLINE IS FLAMMABLE Allow the engine to cool at least ten minutes before refueling.
	WARNING— CARBON MONOXIDE Never run an engine indoors or in a poorly ventilated area. Engine exhaust contains carbon monoxide, an odorless and deadly gas.
	WARNING— HOT SURFACE Engine parts, especially the muffler, become extremely hot during operation. Allow engine and muffler to cool before touching.



WARNING! Your Responsibility—Restrict the use of this power machine to persons who read, understand and follow the warnings and instructions in this manual and on the machine.

SAVE THESE INSTRUCTIONS!



IMPORTANT SAFETY INFORMATION

TRAINING

1. Read, understand, and follow all instructions on the machine and in the manual(s) before attempting to assemble and operate. Keep this manual in a safe place for future and regular reference and for ordering replacement parts.
2. Be familiar with all controls and their proper operation. Know how to stop the machine and disengage them quickly.
3. Never allow children under 18 years of age to operate this machine. Children 16 and over should read and understand the instructions and safe operation practices in this manual and on the machine and be trained and supervised by an adult.
4. Never allow adults to operate this machine without proper instruction.
5. Many accidents occur when more than one person operates the machine. No helper is allowed to assist in stacking logs.
6. Keep bystanders, pets, and children at least 25 feet from the machine while it is in operation.
7. Never allow anyone to ride on this machine.
8. Never transport cargo on this machine.
9. Hydraulic log splitters develop high fluid pressures during operation. Fluid escaping through a pin hole opening can penetrate your skin and cause blood poisoning, gangrene, or death. Give attention to the following instructions at all times:
 - a. Do not check for leaks with your hand.
 - b. Do not operate machine with frayed, kinked, cracked, or damaged hoses, fittings, or tubing.
 - c. Stop the engine and relieve hydraulic system pressure by cycling the valve control lever from forward to reverse several times while engine is not running; returning to neutral before repairing or adjusting fittings, hoses, tubing, or other system components.
 - d. Do not adjust the pressure settings of the pump or valve.
10. Leaks can be detected by passing cardboard or wood, while wearing protective gloves and safety glasses, over the suspected area. Look for discoloration of cardboard or wood.
11. If injured by escaping fluid, see a doctor immediately. Serious infection or reaction can develop if proper medical treatment is not administered immediately.
12. Keep the operator zone and adjacent area clear for safe, secure footing.
13. If your machine is equipped with an internal combustion engine and is intended for use near any unimproved forest, brush, or grass covered land, the engine exhaust should be equipped with a spark arrestor. Make sure you comply with applicable local, state, and federal codes. Take appropriate firefighting equipment with you.



NEVER use this log splitter for any purpose other than splitting wood. It is designed for this use only. Any other use can cause serious injury or death.



IMPORTANT SAFETY INFORMATION

PRE-OPERATION

1. **BEFORE** operating this log splitter, make sure that you wear safety gear such as goggles or safety glasses, steel toed shoes and tight fitting gloves (without loose cuffs or draw strings). Always wear a protective hearing device when operating this log splitter.
2. **NEVER** wear loose clothing or jewelry that can be caught by moving parts of the log splitter. Keep clothing and hair away from all moving parts when operating this log splitter.
3. Check all safety guards and shields to be sure they are in the proper position. Never operate with safety guards, shields, or other protective features removed.
4. Make sure machine is on a flat, dry, solid ground before operating.
5. **ALWAYS** operate your log splitter in an open area. (Exhaust fumes contain carbon monoxide which can be deadly when inhaled.)
6. **ALWAYS** operate your log splitter in daylight or under good artificial light.
7. **ALWAYS** operate your log splitter on level ground. (Operating on a slope could cause the log splitter to roll over or logs to fall off.)
8. **ALWAYS** block wheels to prevent unintended movement.
9. **ALWAYS** keep the work area clean. Remove split wood around the log splitter immediately so that you don't stumble over it.
10. Check all nuts, bolts and hydraulic fittings are tight to be sure the equipment is in a safe working condition.
11. Both ends of the log should be cut as square as possible to help prevent the log from riding out of the splitter during operation. Do not split logs greater than 20.5 inches in length. Uneven logs (e.g. knotted, curved, etc.) should not be used.
12. **ALWAYS** check the oil level before you start the log splitter. See Page 20.
13. Do not allow familiarity with tools to make you careless. Remember that a careless fraction of a second is sufficient to inflict serious injury.



WARNING:



The operation of any power tool can result in foreign objects being thrown into your eyes, which can result in severe eye damage. Before beginning power tool operation, always wear safety goggles or safety glasses with side shields and, when needed, wear a full face shield and earplugs. We recommend a Wide Vision Safety Mask for use over eyeglasses or standard safety glasses with side shields. Always use eye protection which is marked to comply with ANSI Z87.1.



IMPORTANT SAFETY INFORMATION

OPERATION

1. **BEFORE** starting this machine, review the safe instructions in the manual. Failure to follow these rules may result in serious injury to the operator or bystanders.
2. **NEVER** leave this machine unattended with the engine running.
3. **DO NOT** operate machine while under the influence of alcohol, drugs, or medication.
4. **NEVER** allow anyone to operate this machine without proper instruction.
5. **ALWAYS** operate this machine with all safety equipment in place and working. Make sure all controls are operating properly for safe operation.
6. When loading a log, always place your hands on the side of the log, not on the ends, and never use your foot to help stabilize a log. Failure to do so, may result in crushed or amputated fingers, toes, hand, or foot.
7. **NEVER** use your foot, a rope or any extension device to operate the control lever on the valve. Only use hand.
8. Use only your right hand to operate the controls.
WARNING! When stabilizing log with left hand, remove your hand when the wedge just contacts the log or serious injury may occur.
9. For logs which are not cut square, the least square end of the log should be placed toward the beam and wedge, and the square end placed toward the end plate.
10. **NEVER** place hands or feet between the log and splitting wedge during forward or reverse stroke as this could result in serious injury or death. **NEVER** attempt to load the log splitter when the ram or wedge is in motion.
11. **ALWAYS** keep fingers away from any cracks that open in the log while splitting. They can quickly close and pinch or amputate your fingers.
12. Keep your work area clean. Immediately remove split wood around the machine so you do not stumble over it.
13. **NEVER** straddle or step over the log splitter during operation.
14. **NEVER** reach or bend over the log splitter to pick up a log.
15. **NEVER try to split two logs on top of each other. NEVER try to cross split a log.**
16. **NEVER** operate your log splitter when it is in poor mechanical condition or in need of repair.
17. **NEVER** touch the muffler and other hot areas of the engine during operation. Wait until the engine cools down.
18. **NEVER** tamper with the engine to run it at excessive speeds. The maximum engine speed is preset by the manufacturer and is within safety limits. Refer to the engine owner's manual for your particular log splitter.
19. **NEVER** move the log splitter while the engine is running. Shut off the engine if you are leaving the log splitter, even for a short period of time.
20. **ALWAYS** be careful when moving or lifting the log splitter. Get assistance if it feels too heavy to move by yourself.



IMPORTANT SAFETY INFORMATION

OPERATOR ZONE

ONLY operate the log splitter from the operator zones as shown in the diagrams below. The operator has the safest and most efficient access to the control valve and the beam in this location. Operating the log splitter in another location can result in serious injury or death. See FIGURE 1.

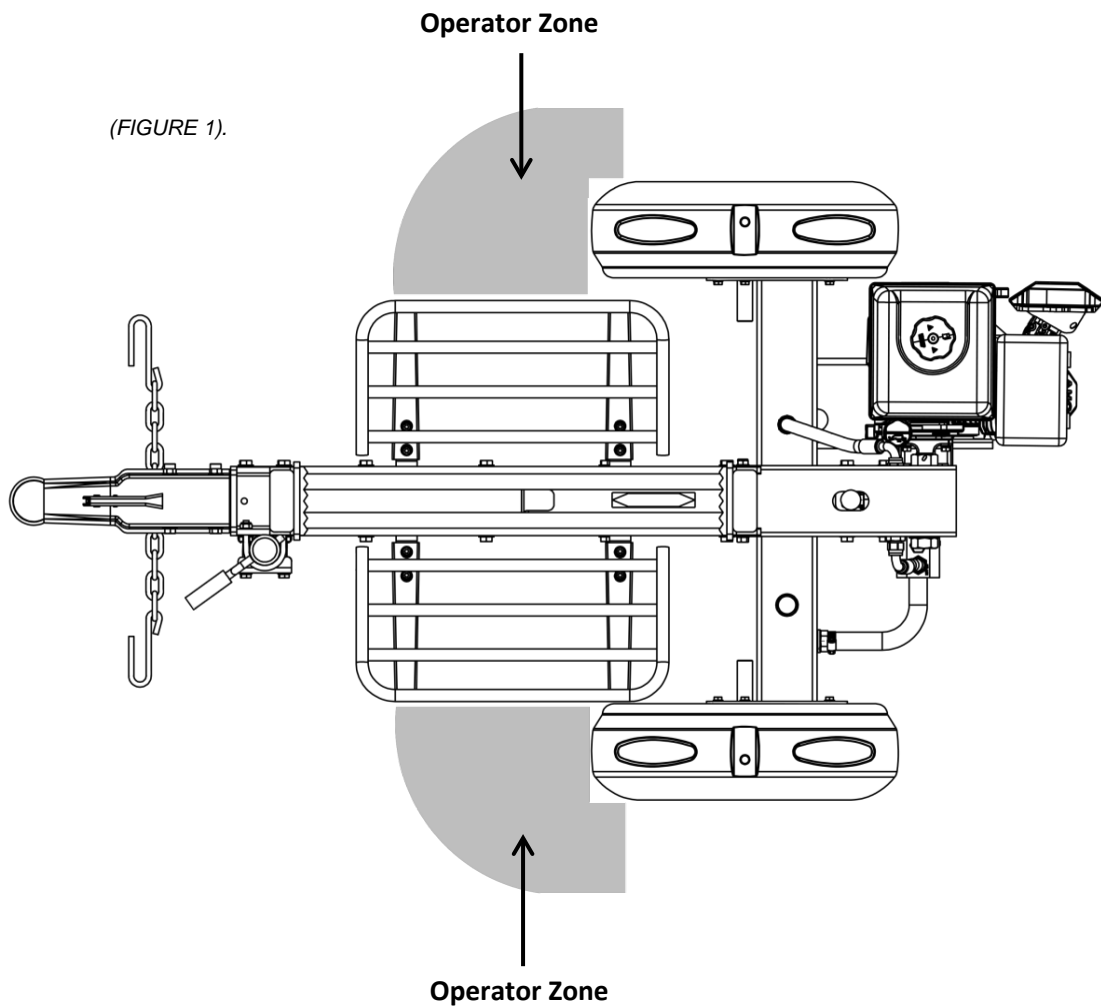



IMPORTANT SAFETY INFORMATION

MAINTENANCE SAFETY

1. Stop the engine, disconnect the spark plug and ground it against the engine before cleaning, or inspecting the machine. **NEVER** perform any service or repair on your log splitter without first removing the spark plug wire.
2. Stop the engine and relieve hydraulic system pressure by cycling the valve control lever from forward to reverse several times while engine is not running; returning to neutral before repairing or adjusting fittings, hoses, tubing, or other system components.
3. **ALWAYS** perform all recommended maintenance procedures before using your log splitter.
4. **ALWAYS** check the level of hydraulic oil and engine oil before operation.
5. **ALWAYS** periodically check that all nuts, bolts, screws, hydraulic fittings and hose clamps are tight to be sure equipment is in safe working condition.
6. **ALWAYS** replace all damaged or worn parts immediately with original equipment manufacturer's (O.E.M.) parts only. Use of parts which do not meet the original equipment specifications may lead to improper performance and compromise safety.
7. The hydraulic system of your log splitter requires careful inspection along with the mechanical parts. Be sure to replace frayed, kinked, cracked or otherwise damaged hydraulic hoses or hydraulic components.
8. **NEVER** check for leaks of hydraulic fluid with your hand. Fluid escaping from a small hole can be almost invisible. Escaping fluid under pressure can have sufficient force to penetrate skin causing **SERIOUS INJURY** or even **DEATH**. Leaks can be safely detected by passing a piece of cardboard over the suspected leak and looking for discoloration.
9. **NEVER** remove the cap from the hydraulic tank or reservoir while the log splitter is running. The tank could contain hot oil under pressure which could result in serious injury.
10. **NEVER** adjust the hydraulic valve. The pressure relief valve on your log splitter is preset at the factory. Only a qualified service technician should perform this adjustment.
11. **ALWAYS** seek professional medical attention immediately if injured by escaping hydraulic fluid. Serious infection or reaction can develop if proper medical treatment is not administered immediately.
12. **ALWAYS** be sure to relieve all pressure by shutting off the engine and moving the valve control handle back and forth should it become necessary to loosen or remove any hydraulic fitting.



NEVER alter your log splitter in any manner. Such alterations may cause your log splitter to be unsafe and will void the warranty.

According to the Consumer Products Safety Commission (CPSC) and the U.S. Environmental Protection Agency (EPA), this product has an Average Useful Life of seven (7) years, or 130 hours of operation. At the end of the Average Useful Life have the machine inspected annually by an authorized service dealer to ensure that all mechanical and safety systems are working properly and not worn excessively. Failure to do so can result in accidents, injuries or death.



IMPORTANT SAFETY INFORMATION

FIRE PREVENTION

1. **ALWAYS** take a Class B fire extinguisher with you when operating this log splitter in dry areas.
2. **NEVER** operate your log splitter near a flame or spark or smoke during operation. Extinguish all cigarettes, cigars, pipes, and other sources of ignition. Hydraulic oil and gasoline are flammable and can explode.
3. To avoid personal injury or property damage use extreme care in handling gasoline. Gasoline is extremely flammable and the vapors are explosive.
4. **ALWAYS** store gasoline in an approved, tightly sealed container, and keep away from heating appliances. Store the container in a cool, dry place.
5. When gasoline is spilled on yourself or your clothes which can ignite wash your skin and change clothes immediately.
6. **NEVER** refuel the gas tank while the engine is hot or running. Allow the engine to cool before refueling.
7. **ONLY** refuel your log splitter in a clear area with no gas fumes or spilled gas. Never fuel machine indoors.
8. Never overfill the fuel tank. Fill tank to no more than 1/2 inch below bottom of filler neck to provide space for fuel expansion.
9. If gasoline is spilled out, wipe it off the engine and equipment and move machine to another area. Wait five (5) minutes before starting the engine.
10. **ALWAYS** replace the gas cap securely. Never remove gas cap while the engine is hot or running.
11. To prevent fires, clean debris and chaff from the engine and muffler areas.
12. Allow machine to cool at least ten (10) minutes before storing.
13. **ALWAYS** drain the fuel tank prior to storage to avoid the potential fire hazard.
14. Never store the machine or fuel container inside where there is an open flame, spark or pilot light as on a water heater, space heater, furnace, clothes dryer or other gas appliances.
15. If the engine is equipped with a spark arrestor muffler, clean and inspect it regularly according to manufacturer's instructions. Replace if damaged.

SPARK ARRESTOR



WARNING!

This log splitter is equipped with an internal combustion engine and should not be used on or near any unimproved forest-covered, brush-covered or grass-covered land unless the engine's exhaust system is equipped with a spark arrester meeting applicable local or state laws (if any). If a spark arrester is used, it should be maintained in effective working order by the operator. In the state of California, a spark arrester is required by law. Other states have similar laws. Federal laws apply on federal lands. A spark arrester muffler is optional and available as an accessory at your nearest engine dealer. Always check the legal requirements in your area.



IMPORTANT SAFETY INFORMATION

TOWING SAFETY

1. **NEVER** carry any cargo or wood on your log splitter.
2. **NEVER** allow anyone to sit or ride on your log splitter.
3. **ALWAYS** turn the fuel shut off valve on the engine to the “OFF” position before towing the log splitter. Failure to do so may result in flooding the engine.
4. **ALWAYS** confirm coupler tightness each time before towing and after towing 50 miles.
5. **ALWAYS** check before towing to make sure that the log splitter is correctly and securely attached to the towing vehicle and that the safety chains are secured to the hitch or bumper of the vehicle with enough slack to allow turning. Always use a Class I, 2” ball with this log splitter.
6. **NEVER** exceed weight capacity of ball or load limits of coupler. **ALWAYS** replace ball or coupler if damaged.
7. **NEVER exceed 45 mph when towing your log splitter.** Towing the log splitter at speeds higher than 45 mph could result in loss of control, damage to the equipment, or serious injury or death. Adjust towing speed for terrain and conditions.
8. **ALWAYS** be careful when backing up with your log splitter in tow. It could jackknife.
9. **ALWAYS** allow for added length of your log splitter when turning, parking, and crossing intersections and in all driving situations.
10. **ALWAYS use safety chains when towing your log splitter.**
11. Be extra cautious when towing over rough terrain, especially railroad crossings, and avoid sharp turns and steep angles when towing your log splitter.
12. Never attempt to move this machine over hilly or uneven terrain without a tow vehicle or adequate help.
13. **ALWAYS** disconnect your log splitter from the towing vehicle before operating it.
14. **ALWAYS** check all local and state regulations regarding towing, licensing, and lights before towing your log splitter. This machine should not be towed on any street, highway or public road without checking the existing federal, state, or local vehicle requirements. Any licensing or modifications such as taillights, etc., needed to comply, is the sole responsibility of the purchaser. If a “Statement of Origin” is required in your state, see your local dealer.
15. See Transporting the Log Splitter section in this manual for proper towing instructions once all federal, local, or state requirements are met.

SAVE THESE INSTRUCTIONS

ASSEMBLY & SET-UP INSTRUCTIONS

UNPACKING THE CONTAINER



WARNING! Use extreme caution unpacking this machine. Some components are very heavy and will require additional people or mechanical handling equipment.

NOTE: All references in this manual to the left or right side and front or back of the log splitter are from the operating position only. Exceptions, if any, will be specified.

Unpacking tools needed:

1. Wrench 14mm
2. Scissors or knife
3. Pry bar or claw hammer

Step 1: Use a 14mm wrench to remove all the bolts and washers securing the side frames on the metal crate, put aside the side frames and hardware just removed, and then lift away the crate top and the cardboard box. See FIGURE 2.

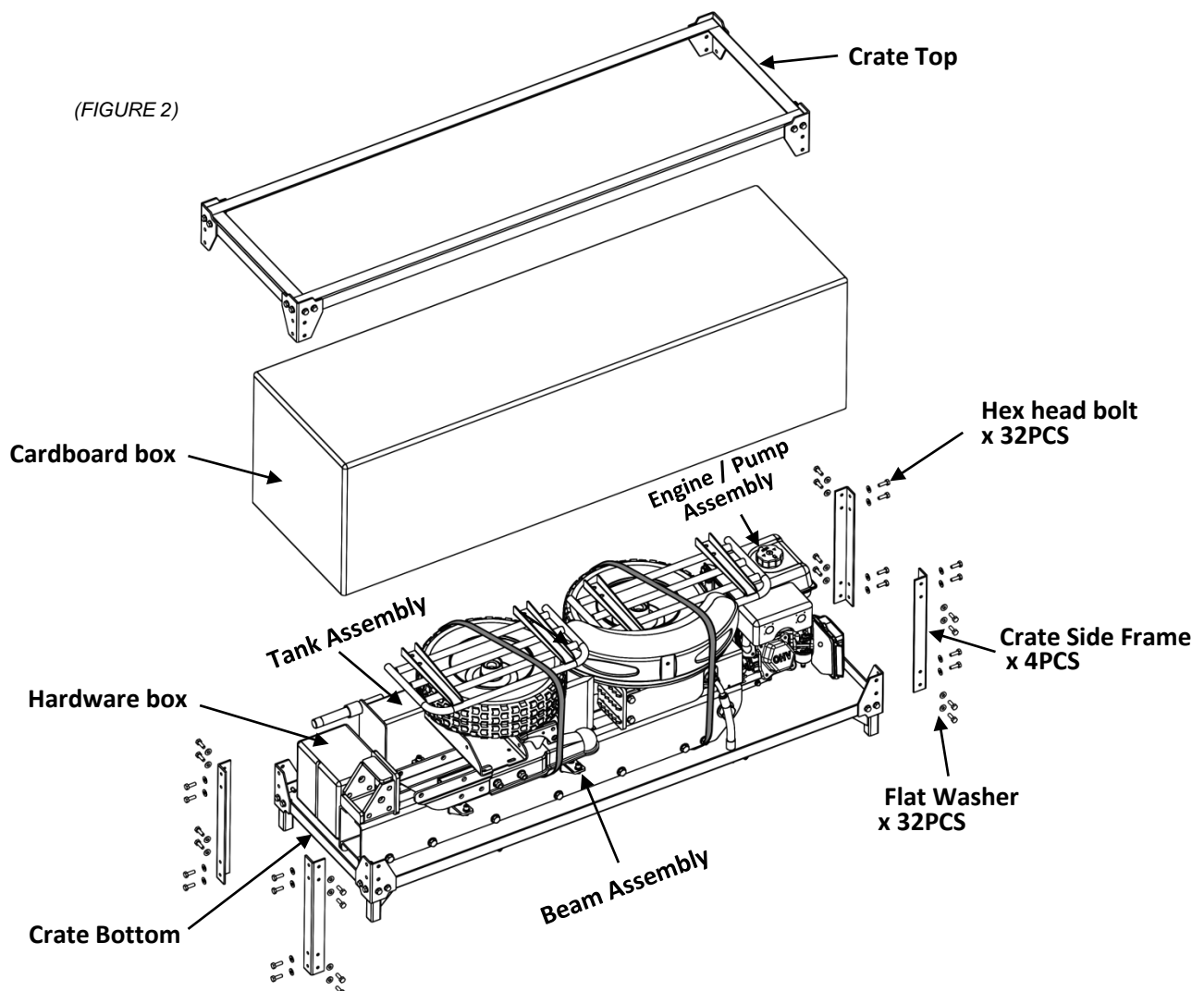

Step 2: Remove all loose parts included in the container, e.g. hardware box.

Step 3: Use scissors or a knife to cut and remove the straps securing the parts to the beam or tank assembly, including fenders, wheels, tongue assembly, log tray assemblies, then put aside these parts for assembly.

NOTE: DO NOT remove the strap securing the hydraulic hoses assemblies to the beam at this time, until you do the assembly procedure of the hoses.

Step 4: Use scissors or a knife to cut and remove the straps securing the engine / pump assembly to the crate bottom, and then place aside carefully for assembly.

Step 5: Use a pry bar or claw hammer to remove the plywood splinters securing the beam and tank assemblies on the crate bottom. Take out the two heavy assemblies.

NOTE: Due to the weight / size of the two assemblies, it's recommended two or more adults to assist lifting and moving the two assemblies. Lifting tools as hoist, crane, jack, etc. are recommended, too.

Step 6: Inspect all component assemblies, parts and accessories according to the packing list attached in this manual (Page 31). Make sure all items listed in the packing list are included, and of no shipping damage.

If any parts are damaged or missing, please call our customer service department at 1-800-780-2677 for assistance.

NOTE: DO NOT discard the packing materials until you have carefully inspected and satisfactorily operated the tool.

ASSEMBLY & SET-UP INSTRUCTIONS

ASSEMBLING

NOTE: Due to the weight / size of the log splitter, it's recommended that two or more adults be present to assist with the assembling. Some lifting tools as hoist, crane, jack, etc. are recommended, too.

Assembling tools needed:

- | | |
|--|---------------------------------|
| 1. Wrench 13mm x 2 | 6. Needle nose pliers x 1 |
| 2. Wrench 14mm x 2 | 7. Allen wrench 3mm x 1 |
| 3. Wrench 16, 17, 18, 19, 27, 32 mm one each | 8. Flat head screwdriver x 1 |
| 4. Wrench 1 / 2" x 1 | 9. Soft faced hammer x 1 |
| 5. Adjustable wrench x 1 | 10. Thread locking compound x 1 |

STEP 1: Install the fenders. See FIGURE 3.

- Loosely secure the fender to the fender support, then loosely secure fender with fender support to the reservoir assembly as shown using the hardware in the Hardware Kit #1.
- Tighten the hardware using two 13mm wrenches.

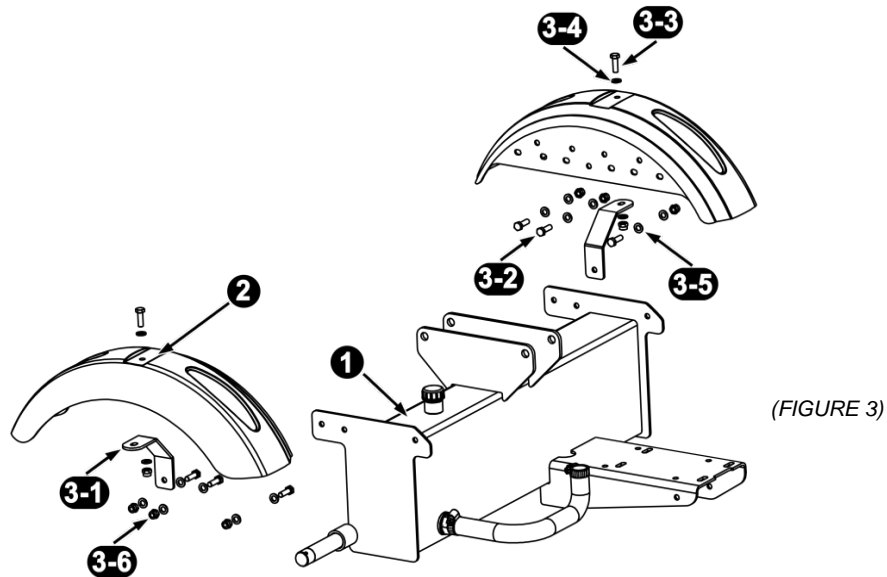

REF. NO.	DESCRIPTION	QTY.
1	Reservoir tank assembly	1
2	Fender	2
3	Hardware Kit #1, including:	1
3-1	Fender support	2
3-2	Hex head bolt / M8 x 25	2
3-3	Hex head bolt / M8 x 20	6
3-4	Flat washer / Ø9 x Ø24 x 1.5	2
3-5	Flat washer / M8	14
3-6	Lock nut / M8	8

STEP 2: Install the two wheels. See FIGURE 4.

1. Block the reservoir tank assembly off the ground. Remove the plastic shipping caps from the wheels, then position the wheels onto the wheel axels.
2. Screw the castle nuts onto the axels and tighten with an adjustable wrench to seat the bearings. Then back the castle nuts off and snug them up to the bearings slightly.
3. Insert the split pin into the slot of castle nut and the hole in the axel, then bend the ends of the pin with needle nose pliers.
4. Tap the dust caps onto the wheel using a soft faced hammer.

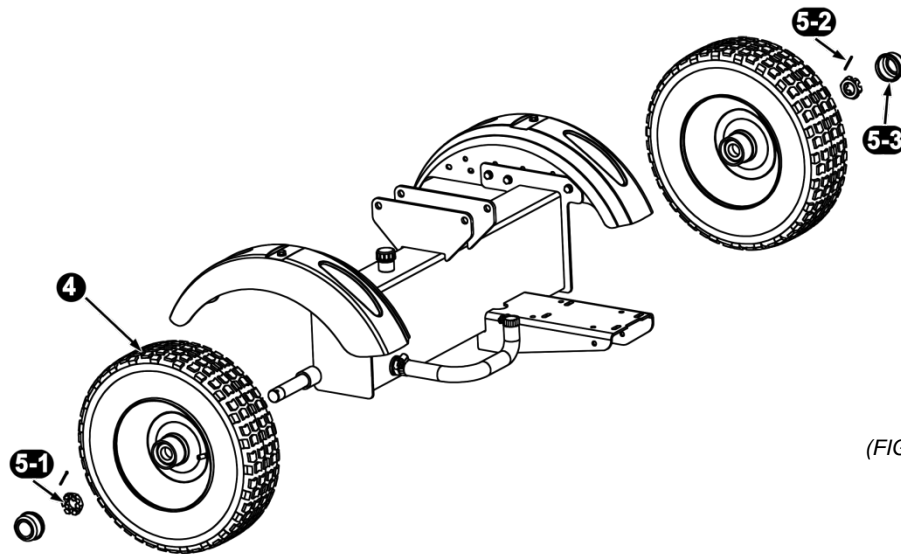

(FIGURE 4)

REF. NO.	DESCRIPTION	QTY.
4	Off- Road tire / Wheel	2
5	Hardware Kit #2, including:	1
5-1	Castle nut / 1-14	2
5-2	Split pin / Ø4 x 50	2
5-3	Dust cap	2

STEP 3: Install the beam assembly. See FIGURE 5

1. Block the beam assembly off the ground. Two or more people are recommended to assist with raising the beam as it is very heavy. Lifting tools as hoist, crane, jack, etc. are strongly recommended. Be sure to keep hands away from any possible pinch points.
2. Screw off the 4 sets of M12 hardware on both sides of the rear end of the beam.
3. Position the tank assembly so that the beam support bracket is in between the slot under the beam.
4. Slide the Bolts M12 x 40 just removed through the aligned holes and tighten the hardware using a 18mm wrench for bolts and a 19mm wrench for the lock nuts. You may need another helper to lift up the tongue for the holes to align.

(FIGURE 5)

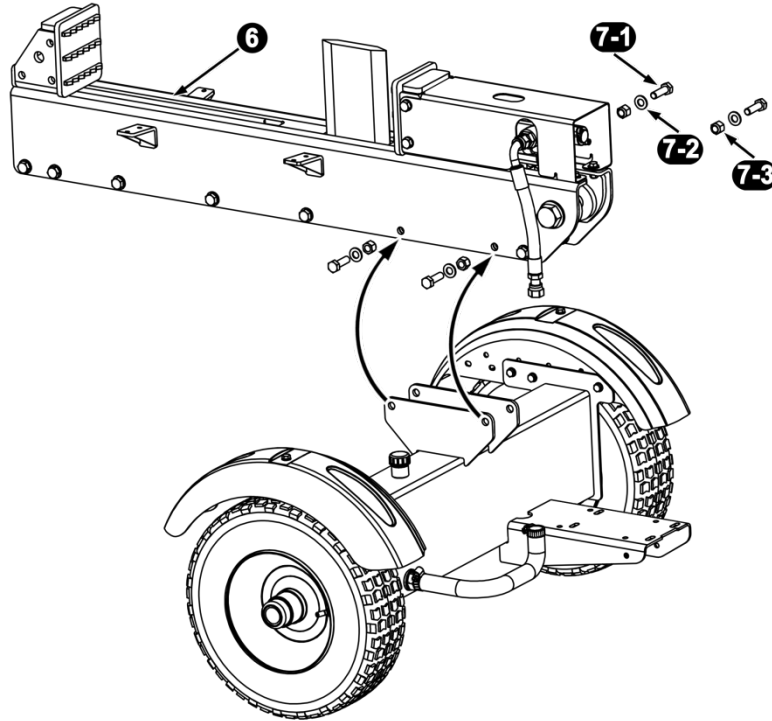

REF. NO.	DESCRIPTION	QTY.
6	Beam assembly	1
7	Hardware mounted on the beam , including:	
7-1	Hex head bolt / M12 x 35	4
7-2	Flat washer / M12	4
7-3	Lock nut / M12	4

STEP 4: Install the tongue assembly. See FIGURE 6

1. Screw off the 6 sets of M12 hardware on both sides of the front end of the beam.
2. Position the tongue assembly so that the mounting bracket is in between the slot under the beam.
3. Slide the Bolts M12 x 40 just removed through the aligned holes and tighten the hardware using a 18mm wrench for bolts and a 19mm wrench for the lock nuts.

(FIGURE 6)

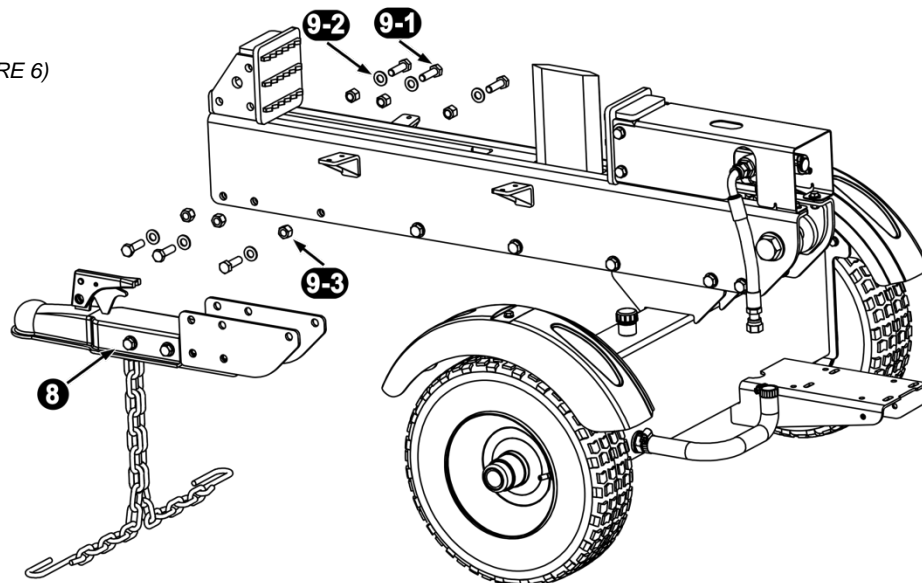

REF. NO.	DESCRIPTION	QTY.
8	Tongue assembly	1
9	Hardware mounted on the beam , including:	
9-1	Hex head bolt / M12 x 35	6
9-2	Flat washer / M12	6
9-3	Lock nut / M12	6

STEP 5: Install the wheeled trailer jack assembly. See FIGURE 7.

1. Position the wheeled trailer jack against the front end of the beam.
2. Slide the two threaded ends of U-bolt through the two bottom holes on the side bracket of front end plate, and secure with the M10 washers and lock nuts loosely.
3. Position the two jack clamp between the two annular bulges on the trailer jack, align the holes on the clamps with the two holes on the tongue mounting bracket, and then secure with the M10 hardware loosely.
4. Adjust the trailer jack and make sure the cranking handle sticking out to the front / left direction.
5. Tighten all M10 hardware using a 16mm wrench on the bolts, and a 17mm wrench on the lock nuts.

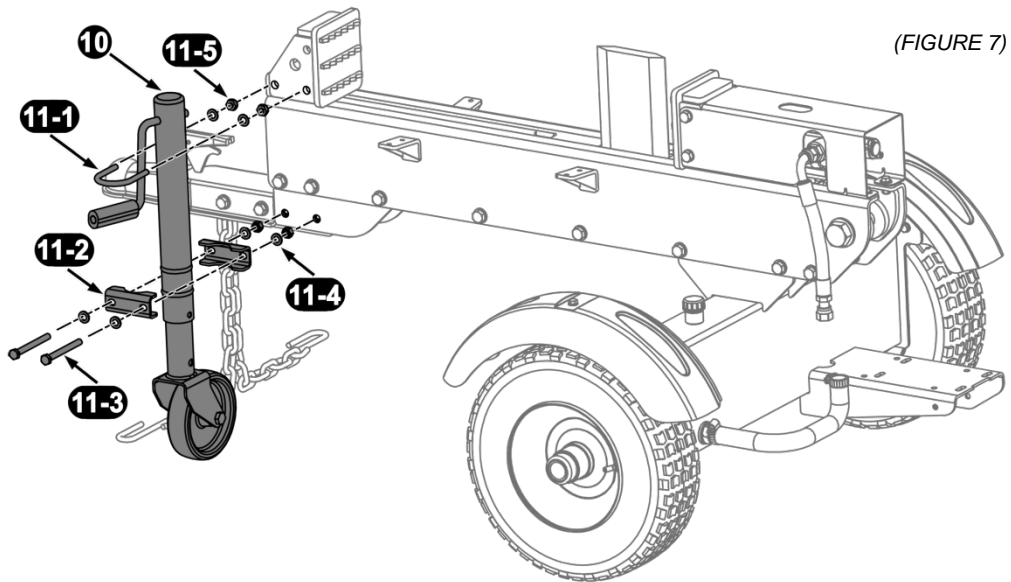

(FIGURE 7)

REF. NO.	DESCRIPTION	QTY.
10	Wheeled trailer jack	1
11	Hardware Kit # 4-1 (13T), or 4-2 (16T) including:	1
11-1	U-bolt / M10 x 190	The same
11-2	Jack Clamp / W26	or Jack Clamp / W35.5
11-3	Hex head bolt / M10 x 130	The same
11-4	Flat washer / M10	The same
11-5	Lock nut / M10	The same
		4

STEP 6: Connect the oil return hose. See FIGURE 8.

1. The oil return hose 1/2", has one end fixed on the right side of the valve on the beam assembly by manufacturer, the other open end needs to be attached, which is labeled as ③ for easy installation
2. Screw the open end of this hose onto the fitting on top of the reservoir, which is labeled of a same ③. Tighten the hose using a 27mm wrench or an adjustable wrench.

(FIGURE 8)

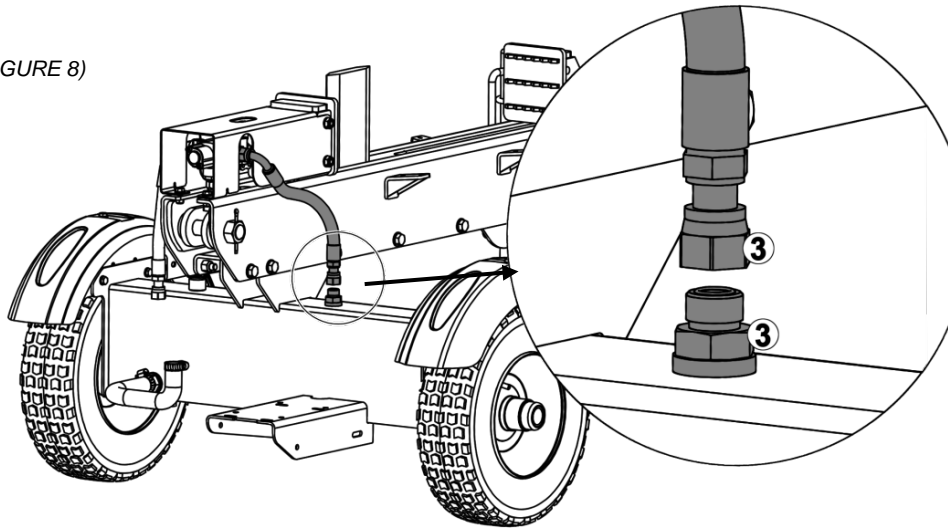

STEP 7: Install the engine / pump assembly. See FIGURE 9.

1. Insert vibration isolator each between the engine and the mount plate at the four mounting hole positions.
2. Secure the engine with the M8 hardware, then tighten the hardware using two 13mm wrenches.

(FIGURE 9)

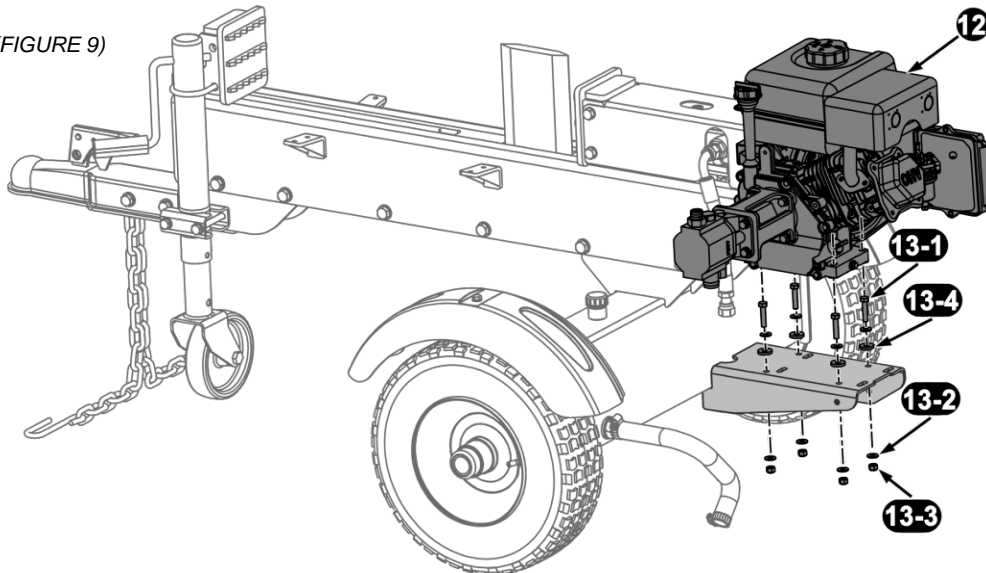

REF. NO.	DESCRIPTION	QTY.
12	Engine / Pump assembly	1
13	Hardware kit # 5-1, including:	1
13-1	Hex head bolt / M8 x 40	4
13-2	Flat washer / M8	8
13-3	Lock nut / M8	4
13-4	Vibration isolator / Ø9	4

STEP 8: Attach the oil suction hose and Pump / Valve connecting hose. See FIGURE 10.

The two hydraulic hoses listed below, each of them has one end fixed on the log splitter by manufacturer, the other open end needs to be attached.

1. Oil suction hose $\frac{3}{4}$ " , labeled as ①, comes from the bottom of the reservoir. Loosen the hose clamp on the open end of this hose using a flat head screwdriver, and then connect the hose to the fitting on the bottom of the pump, which is labeled of a same ①. Tighten the hose clamp.

- Pump / Valve connecting hose ½", labeled as ②, comes from the left side of the valve on the beam assembly. Screw the open end of this hose onto the fitting on top of the pump, which is labeled of a same ②. Tighten using a 27mm wrench or an adjustable wrench.

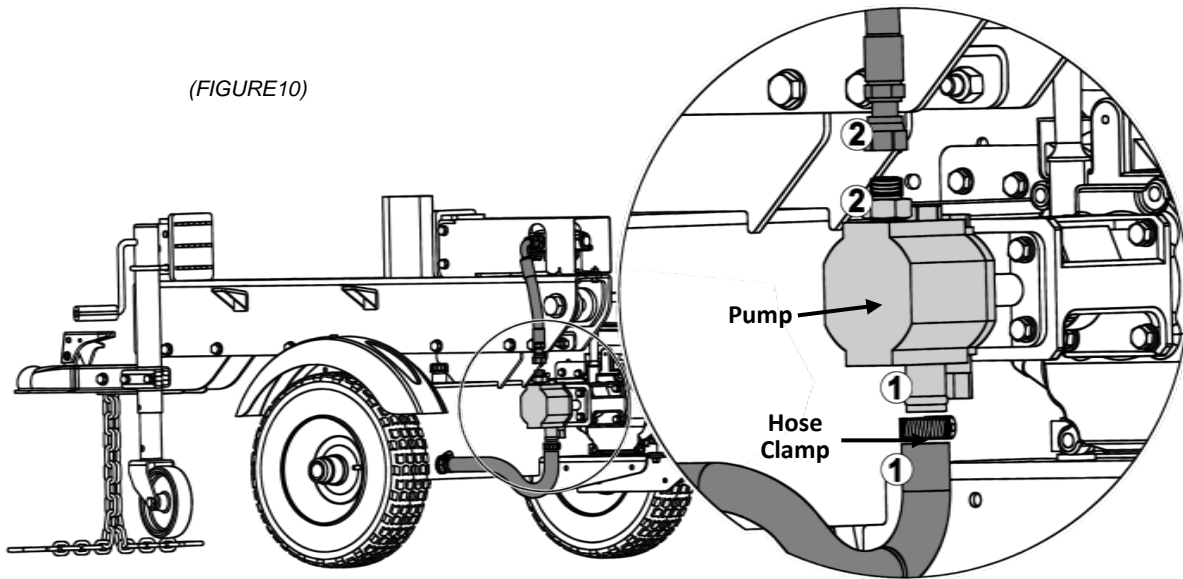

STEP 9: Install the log tray assemblies and control handle lever. See FIGURE 11.

- Position the log tray frames onto the tabs on both sides of the beam as shown, and secure with the M8 hardware using a 13mm wrench.
- Screw the control handle lever into its linkage part on top of the valve.

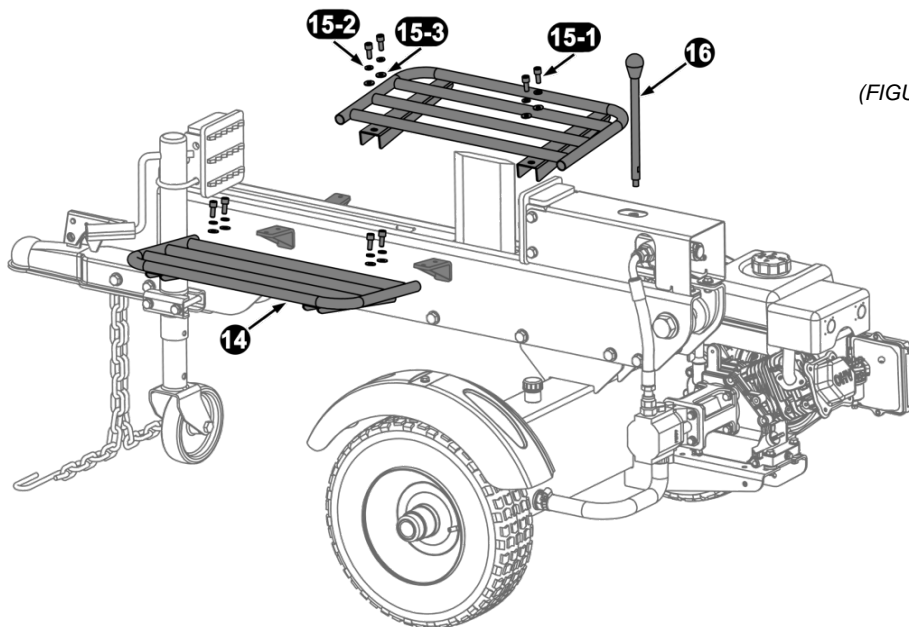

REF. NO.	DECSRIPTION	QTY.
14	Log tray	2
15	Hardware Kit #7, including:	1
15-1	Inner Hex head bolt / M8 x 20	8
15-2	Spring washer / M8	8
15-3	Flat washer / M8	8
16	Control handle lever	1

ASSEMBLY & SET-UP INSTRUCTIONS

SET-UP

Gas and Oil Fill-Up

Service the engine with gasoline and engine oil as instructed in the engine manual packed with your log splitter. Read the instructions carefully.



WARNING! Use extreme care when handling gasoline. Gasoline is extremely flammable and the vapors are explosive. Never fuel the machine indoors or while the engine is hot or running.

NOTE: Your log splitter may be shipped without engine oil. You **MUST** check the oil level before operating. Be careful not to overfill. Gasoline can be added to the engine when the log splitter is in either the horizontal or vertical position. However, it may be easier when the splitter is in the vertical position.

Know Controls and Features

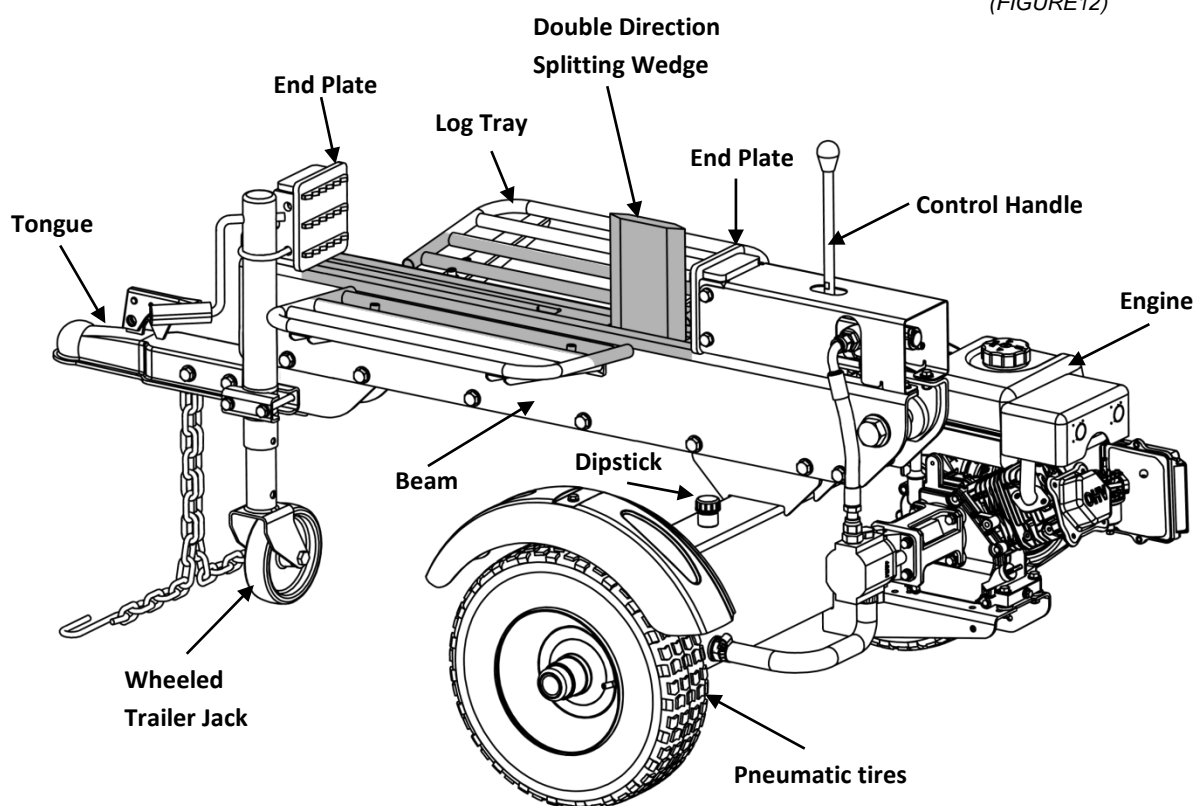

NOTE: This Operator's Manual covers several models. Log splitter features may vary by model. Not all features in this manual are applicable to all log splitter models and the log splitter depicted may differ from yours.

Lubricate the Beam

Lubricate the beam area (where the splitting wedge will slide) with engine oil. Do not use grease. See FIGURE 12.

Fill hydraulic oil

The log splitter is shipped without hydraulic fluid in the reservoir. Fill the reservoir before your initial use.

1. Remove the vented reservoir dipstick, which is located on top of the reservoir tank. See FIGURE 17.

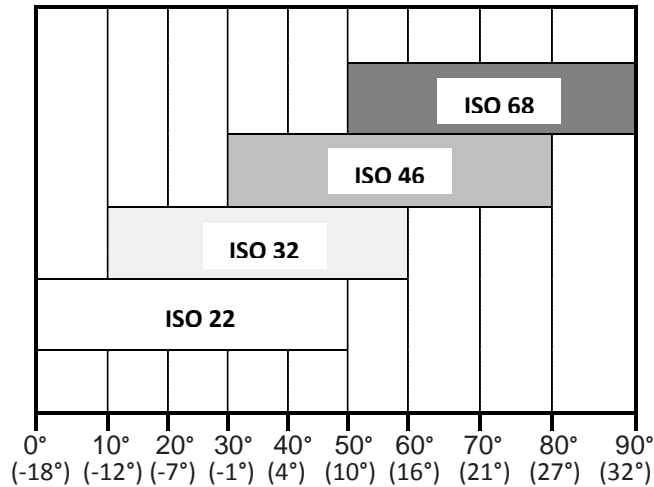

Please select the oil based on the outside temperature range the log splitter will be used in. Refer to the chart provided to select the appropriate hydraulic oil.

Approved fluids include Shell Tellus® S2 M 32 Hydraulic Fluid, Dexron® III / Mercon® automatic transmission fluid, Pro-Select™ AW-32 Hydraulic Oil or 10WAW-ISO viscosity grade 32 hydraulic oil. It is not recommended that fluids be mixed, to top off the reservoir tank during initial set-up use Shell Tellus® S2 M 32 Hydraulic Fluid only.

2. Slowly fill the reservoir tank with the recommended hydraulic oil until oil level reach the maximum line on the dipstick.
3. Replace the vented dipstick in the reservoir.
4. Start the engine, and use the control handle to engage the wedge to the farthest extended position, and then retract. Repeat this operation for 12 cycles. Much of the fluid will be drawn into the cylinder and hoses. Stop the engine, and check the oil level as instructed below.

NOTE: Make sure the oil level is above the bottom line on the dipstick. If not, refill the reservoir to prevent damage to the hydraulic pump. **DO NOT overfill.** Some fluid may overflow from the vent plug as the system builds heat and the fluid expands and seeks a balanced level

5. However, you **MUST** check the fluid level before each operating. If not filled, proceed with above steps:

(FIGURE13)

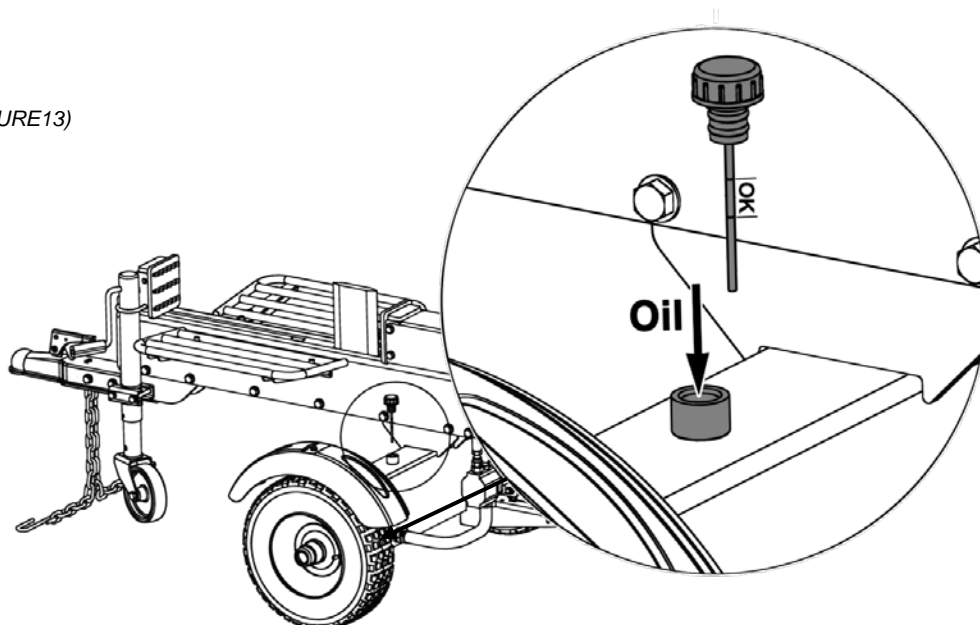

OPERATION INSTRUCTIONS

STARTING & STOPPING THE ENGINE

1. Place the log splitter on flat, dry, solid ground.
2. Block both wheels to prevent your log splitter from moving during operation.
3. Refer to the Engine Operator's manual packed with your log splitter for instructions on starting and stopping the engine.

USING CONTROL HANDLE

The control handle has three positions. See FIGURE 14.

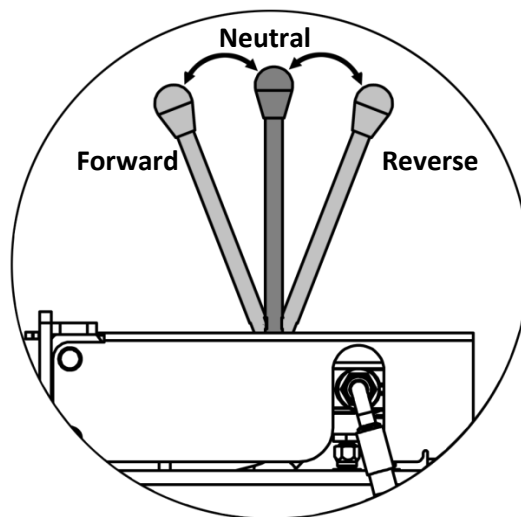

(FIGURE14)

- **FORWARD** — To split wood in forward direction. Move the control handle to the FORWARD position to move wedge toward the log to split.
- **NEUTRAL** — To stop wedge. The control handle will return to the NEUTRAL position as soon as the handle is released, and the wedge stops moving at any point during splitting.
- **REVERSE** — To split wood in reverse direction. Move the control handle to the REVERSE position to move the wedge backward into another log to split.

NOTE: Do not hold the handle in the FORWARD or REVERSE positions when the wedge is fully extended or retracted.



WARNING! If the control handle on your log splitter is not functioning properly, STOP USE IMMEDIATELY and contact an authorized service dealer.



WARNING! Do not attempt to service, repair or replace control valve. Contact an authorized service dealer.



WARNING! Do not attempt to adjust or modify the control valve or the hydraulic system from its original settings or manufacturer in any way.

OPERATION INSTRUCTIONS

SPLITTING THE WOOD

1. Start the engine as instructed in the Engine Operator's manual included with the log splitter.
2. Grasp the log on the sides, place it on top of the beam against the front end plate to split the wood in the direction of the grain. See FIGURE 15.
3. To stabilize the log, place your left hand on the side of the log. See FIGURE 15.



WARNING! Never place a hand on the ends of the log, between the log and the end plate or the log and the splitting wedge.



WARNING! Only one operator permitted. The adult who loads and stabilizes the log, must be the person who operates the control handle.

4. Use your right hand to push the control handle lever to the forward position to split the wood.
5. Remove left hand from the side of the log once the wedge just contacts the log. Continue moving control handle forward to split the log.
6. Release the control handle to stop the wedge movement at any point in the splitting process, if you feel an unsafe splitting condition is occurring. **NEVER** reach crossly and attempt to catch a falling split wood---let it fall. The control handle will return to the Neutral position automatically when you release it.
7. Once the log split or the wedge fully extended, load another log between the wedge and the back end plate, and pull the control handle backward to split the log.

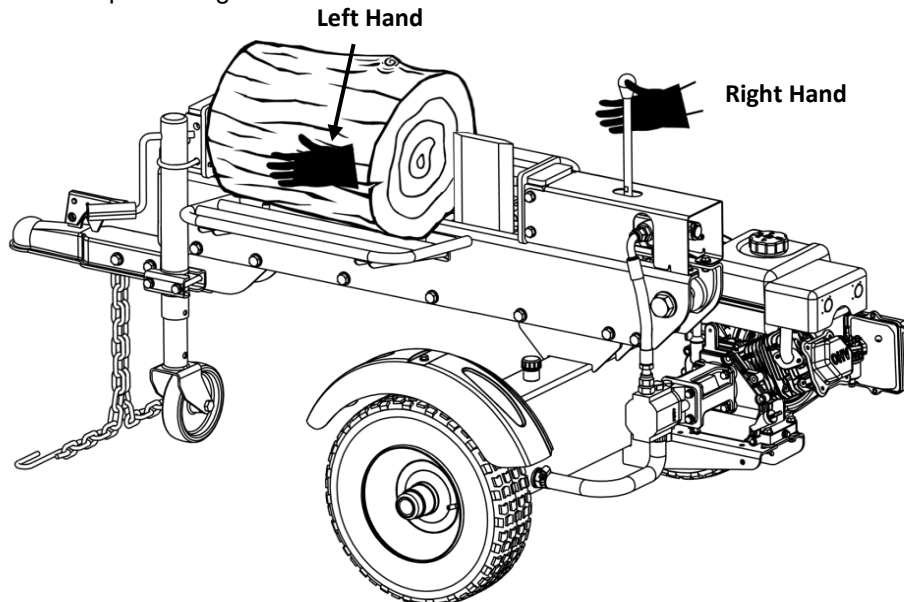

(FIGURE15)

8. Remove partially split wood from wedge.
 - 1) If the log is clipped or jammed on the wedge, release the control handle and shut off the engine immediately. Gently knock off the log with a hammer or mallet (not with your hands).



WARNING! Never remove partially split wood from the wedge with your hands. Fingers may become trapped between the split wood.

- 2) Once removed from the wedge, split the wood from the opposite end or in another location.

OPERATION INSTRUCTIONS

TRANSPORTING THE LOG SPLITTER

1. This log splitter has a built-in wheeled trailer jack for easy maneuvering.
2. Swing the jack up or down using the cranking handle on the jack, to position the hitch coupler over the tow ball behind your vehicle. See FIGURE 16
3. Pull the latch on the hitch coupler up, place the coupler onto the tow ball, and then close the latch to lock the ball securely.
 - 1) If the coupler hitch does not fit on the ball, turn the adjustment nut one turn counter-clockwise.
 - 2) If the coupler hitch is too loose on the ball, turn the adjustment nut one turn clockwise. Then recheck and adjust accordingly.
4. Attach the safety chains to the towing vehicle crossing each other under the tow ball, and ensuring there is enough slack for turning.
5. Insert the locking pin into the hole in the latch assembly, and lock with the sprig clip.

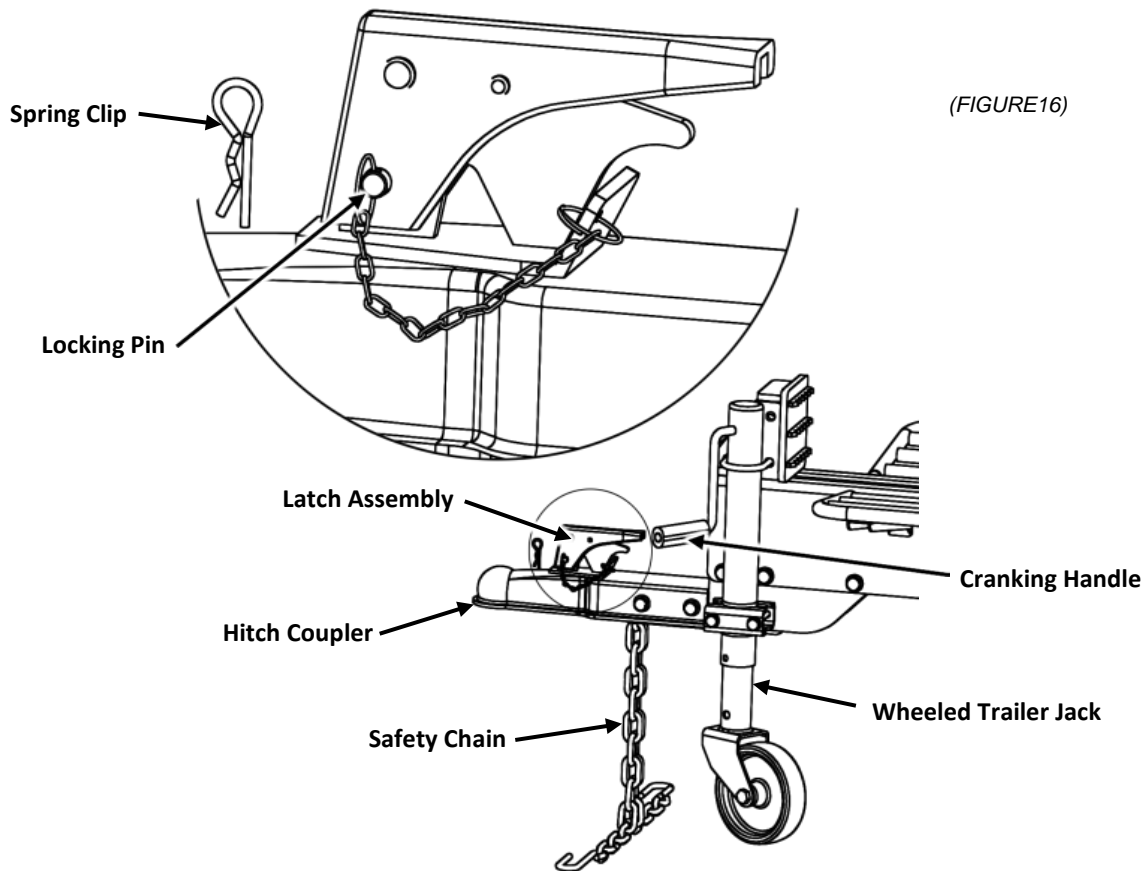

WARNING! Do not tow faster than 45mph and check the local, state and federal requirements before towing on any public road.

NOTE: Use caution when backing up, using a spotter outside the vehicle is recommended.

MAINTENANCE & ADJUSTMENTS

Regular maintenance is the way to ensure the best performance and long life of your machine. Please refer to this manual and the engine manufacturer's owner's manual for maintenance procedures.



WARNING! Do not make any adjustments without first stopping the engine, disconnecting the spark plug wire and grounding it against the engine. Always wear safety glasses during operation or while performing any adjustments or repairs.

Engine

Refer to the Engine Operator's manual packed with your log splitter for all engine maintenance e.g. how to check and change the engine oil.

NOTE: When draining oil from the engine on this log splitter, shield the hoses from any oil that may run down the frame and drip onto the hoses. Thoroughly wipe any residual oil off the log splitter and hoses after completing service.

Tire Pressure

The tires coming with your log splitter are pneumatic off-road tires. The max recommended operating pressure is 30 psi. Do not, under any circumstances, exceed the manufacturer's recommended psi. Maintain equal pressure on all tires.



WARNING! Excessive pressure when seating beads may cause the tire/rim assembly to burst with force sufficient to cause serious injury.

Flexible Pump Coupler

The flexible pump coupler, located between the pump and the engine shaft, has a nylon "spider" insert. Over time, the insert will harden and deteriorate. If you detect vibration or noise coming from the area between the engine and the pump contact an authorized dealer or Boss Industrial, Inc. Change a new coupler spider immediately, if the coupler fails completely, you will experience a loss of hydraulic power.

Hydraulic Fluid

Check the hydraulic fluid level in the log splitter reservoir tank before each use. Maintain the fluid level within the range specified on the dipstick at all times.

Change the hydraulic fluid in the reservoir every 100 hours of operation. Follow the steps below:

1. Place a suitable oil collection container under the tank.
2. Disconnect the oil drain screw from the bottom of the reservoir tank. See FIGURE 17.
4. Allow the fluid to drain into the container.

NOTE: The reservoir tank has a capacity of 4 gallons of hydraulic fluid.

5. After draining, screw on the oil drain screw and tighten.

(FIGURE17)

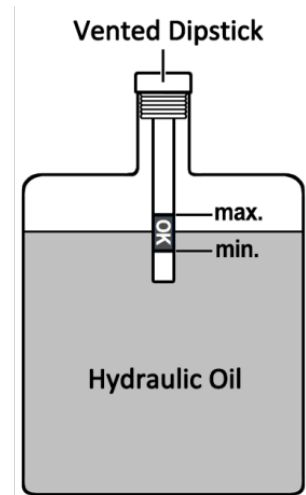
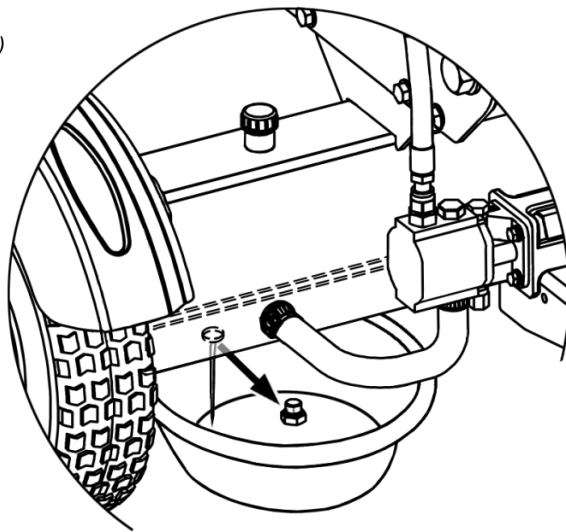

(FIGURE18)

6. Refill the reservoir tank (Please follow the steps in Page 20 to fill the tank, and repel the air in the tank) .
7. Maintain the fluid level within the range specified on the dipstick at all times. See FIGURE 18.

NOTE: When checking the fluid, always make sure to tighten the dipstick until the top of the threads are flush with the top of the pipe.

NOTE: Always dispose of any used hydraulic fluid and engine oil at approved recycling centers only. Contaminants in the fluid may damage the hydraulic components. Flushing the reservoir tank and hoses with kerosene whenever service is performed on the tank, hydraulic pump or valve is recommended.

Beam and Splitting Wedge

Lubricate top, sides and bottom of the beam and where it comes into contact with the splitting wedge with engine oil before each use.

If the wedge becomes dull or nicked, it can be sharpened.

Off-Season Storage

If the log splitter will not be used for more than 30 days, prepare it for storage as follows:



WARNING! Never store the machine with fuel in the fuel tank inside of building where fumes may reach an open flame or spark, or where ignition sources are present such as hot water and space heaters, furnaces, clothes dryers, stoves, electric motors, etc.

1. Refer to the Engine Operator's manual packed with your log splitter for information on the off-season storage of the engine.
2. Clean the log splitter thoroughly.

NOTE: The use of pressure washers or a garden hose to clean the splitter is not recommended. They may cause damage to the bearings or the engine. The use of water will result in a shortened life and reduce serviceability.

3. Wipe the machine with an oiled rag to prevent rust, especially on the wedge and the beam.
4. Store the log splitter in a clean, dry area. Do not store it next to corrosive materials, such as fertilizer.

NOTE: If storing in an unventilated or metal storage shed, be certain to rustproof the equipment by coating it with a light oil or silicone.

TROUBLESHOOTING

Most problems are easy to fix. Consult the trouble shooting Table below for common problems and their solutions. If you continue to experience problems, contact us at www.boss-industrial.com, or call toll-free (800) 780 2677 for support.

If the machine should start making an unusual noise or vibration, shut down the engine, wait 5 minutes for machine to cool down, then inspect for damage. Vibration is generally a warning of trouble. Check for damaged parts and clean, repair and / or replace as necessary.

Problem	Cause	Remedy
Cylinder rod will not move	<ol style="list-style-type: none"> 1. Broken drive shaft. 2. Shipping plugs left in hydraulic hoses. 3. Set screws in coupling not adjusted properly. 4. Loose shaft coupling. 5. Gear sections damaged. 6. Damaged relief valve. 7. Hydraulic lines blocked. 8. Low oil level or air trapped in hydraulic system. 9. Damaged control valve. 10. Blocked control valve. 	<ol style="list-style-type: none"> 1. See authorized service dealer. 2. Disconnect hydraulic hoses, remove shipping plugs, and reconnect hoses. 3. See authorized service dealer. 4. Correct engine/pump alignment as necessary. 5. See authorized service dealer. 6. See authorized service dealer. 7. Flush and clean hydraulic system. 8. Fill oil or bleed air. 9. See authorized service dealer. 10. Flush and clean hydraulic system
Slow cylinder shaft speed while extending and retracting	<ol style="list-style-type: none"> 1. Gear sections damaged. 2. Excessive pump inlet vacuum. 3. Slow engine speed. 4. Damaged relief valve. 5. Low oil level or air trapped in hydraulic system. 6. Contaminated oil. 7. Control valve leaking internally. 8. Internally damaged cylinder. 	<ol style="list-style-type: none"> 1. See authorized service dealer. 2. Make certain pump inlet hoses are clear and unblocked. Use short, large diameter inlet hoses. 3. See authorized service dealer. 4. See authorized service dealer. 5. Fill oil or bleed air. 6. Drain oil, clean reservoir and refill. 7. See authorized service dealer. 8. See authorized service dealer
Leaking Cylinder	<ol style="list-style-type: none"> 1. Worn seals. 2. Scored cylinder. 	<ol style="list-style-type: none"> 1. See authorized service dealer. 2. See authorized service dealer.
Wood will not split or wood splits too slowly	<ol style="list-style-type: none"> 1. Small gear section damaged. 2. Pump check valve leaking. 3. Excessive pump inlet vacuum. 4. Low oil level or air trapped in hydraulic system. 5. Contaminated oil. 6. Control valve leaking internally. 7. Overloaded cylinder. 8. Internally damaged cylinder. 	<ol style="list-style-type: none"> 1. See authorized service dealer. 2. See authorized service dealer. 3. Make certain pump inlet hoses are clear and unblocked. 4. Fill oil or bleed air. 5. Drain oil, clean reservoir and refill. 6. See authorized service dealer. 7. Do not attempt to split wood against the grain. 8. See authorized service dealer.
Leaking pump shaft seal	<ol style="list-style-type: none"> 1. Broken drive shaft. 2. Engine/pump misalignment. 3. Gear sections damaged. 4. Damaged shaft seal. 5. Plugged oil breather. 	<ol style="list-style-type: none"> 1. See authorized service dealer. 2. Correct alignment as necessary. 3. See authorized service dealer. 4. See authorized service dealer. 5. Make certain reservoir is properly vented.
Wedge continues to move forward when control handle is released	<ol style="list-style-type: none"> 1. Damaged control valve 	<ol style="list-style-type: none"> 1. See authorized service dealer.
Control handle does not return to neutral when released from forward position	<ol style="list-style-type: none"> 1. Hydraulic fluid too cold. 2. Hydraulic fluid too thick. 3. Hydraulic fluid contaminated. 4. Damaged control valve. 	<ol style="list-style-type: none"> 1. Warm up engine. 2. Replace hydraulic fluid. 3. Replace hydraulic fluid. 4. See authorized service dealer.

SPECIFICATIONS

Model		GD13T21	GD16T21
Engine		See engine manual	See engine manual
Pump		Two-Stage, 9 gpm	Two-Stage, 11 gpm
Cylinder (Bore x Stroke)		3 in. x 18.4 in.	3.5 in. x 18.4 in.
Maximum Splitting Force		13 Tons*	16 Tons*
Hydraulic Pressure		3700 psi*	3400 psi*
Maximum Log Length		20.5 in.	20.5 in.
Wedge Height		6.5 in.	6.5 in.
Cycle Time	Forward	4 Seconds*	6 Seconds*
	Reverse	3.5 Seconds*	5.5 Seconds*
Wheels		16 x 4.8 x 8 in.	16 x 4.8 x 8 in.
Hydraulic Capacity		4 Gallons	4 Gallons
Height		37.5 in.	38 in.
Length		71.5 in.	71.5 in.
Width		40.5 in.	40.5 in.
Net Weight		315 lbs	342 lbs

*Tonnage and cycle times may vary dependent upon mechanical and environmental conditions.



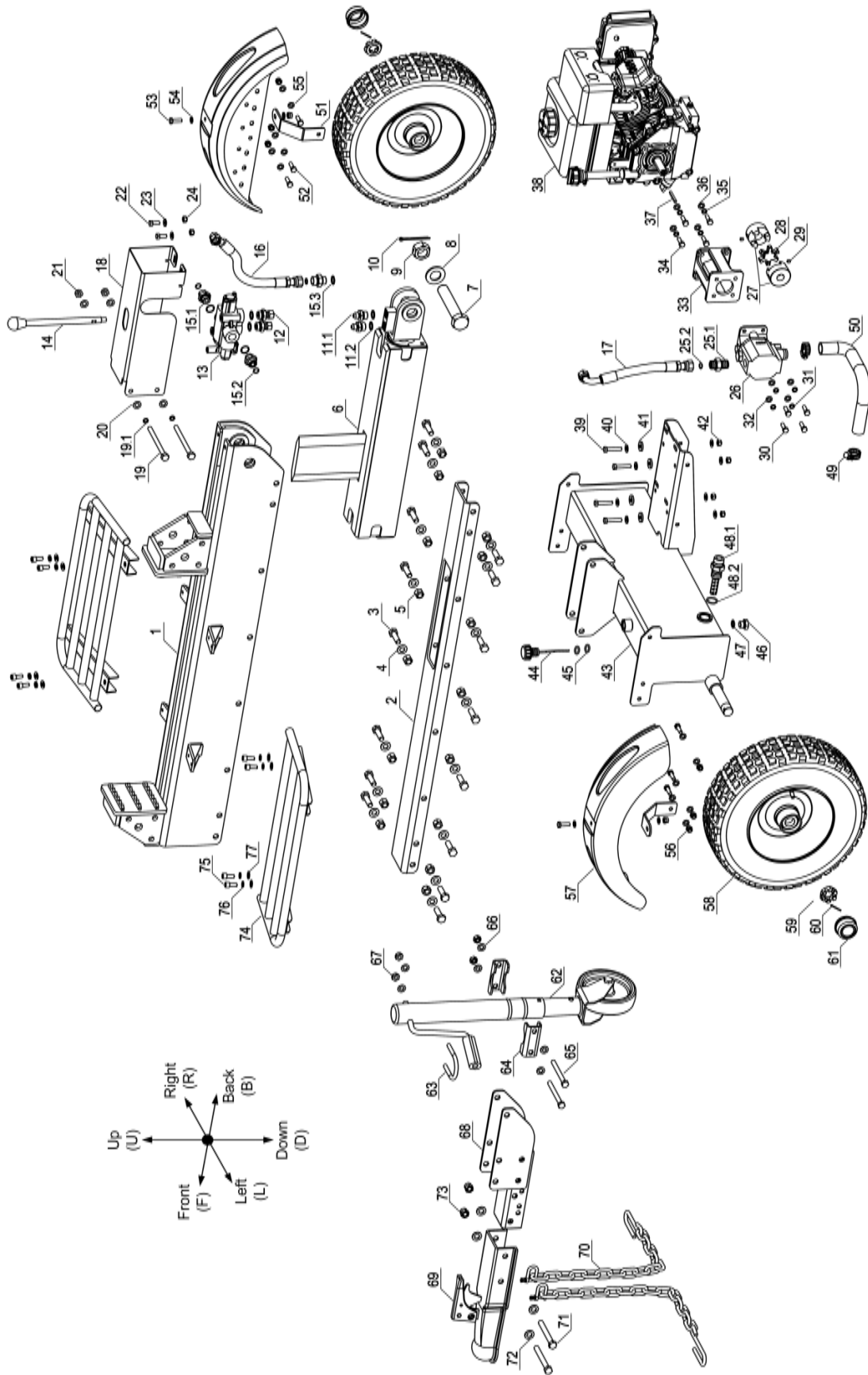

EXPLODED DIAGRAM & PARTS LIST

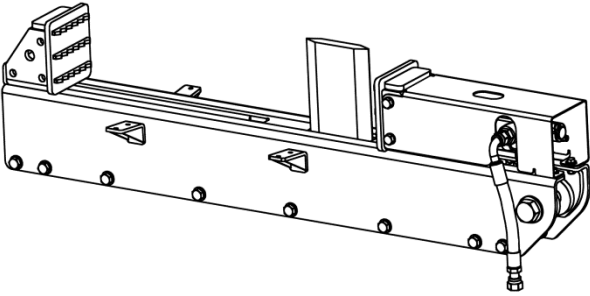
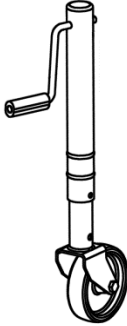
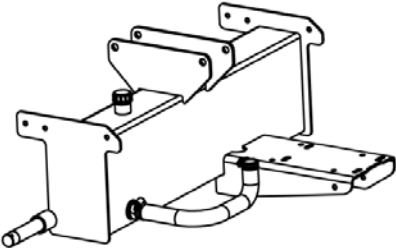
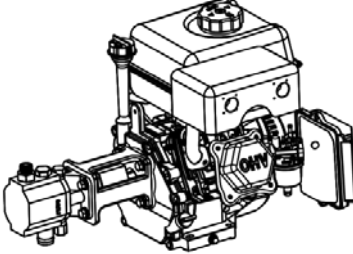
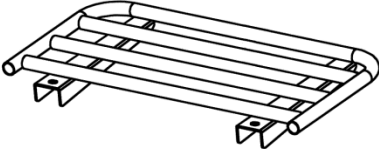
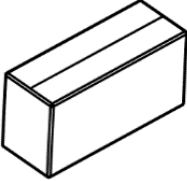

REF #	PART #	PART NAME	SPECIFICATIONS	QTY PER UNIT
1	310-850	Machine Body incl. End Plates 13 Ton	115*298*6mm/130*140*10	1
	310-853	Machine Body incl. End Plates 16 Ton	130*307*8mm/150*140*10	
2	310-851	Machine Body Bottom 13 Ton	W100	1
	310-854	Machine Body Bottom 16 Ton	W114	
3	710-438	Hex Head Bolt	ZP, M12*35	16
4	750-621	Flat Washer	ZP, M12	16
5	720-536	Lock Nut	ZP, M12	16
6	530-480	Cylinder, 13 Ton	3.0 in.	1
	530-482	Cylinder, 16 Ton	3.5 in.	
7	760-137	Pin, 13 TON	PH, M27*141	1
	760-132	Pin, 16 TON	PH, M32*165	
8	750-623	Flat Washer, 13 Ton	PH, M27*4	1
	750-677	Flat Washer, 16 Ton	PH, M32*6	
9	720-815	Bored Nut, 13 Ton	PH, M27	1
	720-872	Bored Nut, 16 Ton	PH, M32	
10	760-744	Split Pin	Ø4*50	1
11.1	510-211	Hydraulic Adaptor	Straight, Hex24	2
11.2	730-077	O Seal Ring	Ø21*2.4	4
12	510-224	Hydraulic Adaptor	Straight Swing, Hex24/19	2
13	520-766	Hydraulic Valve		1
14	520-405	Control Handle Lever	Ø15*264	1
15.1	510-448	Hydraulic Adaptor	Straight, Hex27*36.5	3
15.2	730-619	O Seal Ring	Ø15*1.9	3
15.3	730-077	O Seal Ring	Ø21*2.4	3
16	560-409	Hydraulic Hose (Valve - Reservoir)	1/2"*350	1
17	560-403	Hydraulic Hose (Pump - Valve)	1/2"*300	1
18	350-200	Valve Cover 13 Ton	W118	1
	350-203	Valve Cover 16 Ton	W135	
19	710-669	Hex Head Bolt 13 Ton	ZP, M10*130 (8.8)	2
	710-614	Hex Head Bolt 16 Ton	ZP, M8*15	
19.1	750-834	Spring washer 16 Ton	ZP, M8	4
20	750-525	Flat Washer, 13 Ton	ZP, M10	4
	750-638	Flat Washer, 16 Ton	ZP, M8	
21	720-120	Lock Nut 13 Ton	ZP, M10	2
22	710-637	Hex Head Bolt	ZP, M8*20 (8.8)	2
23	750-638	Flat Washer	ZP, M8	2
24	720-500	Lock Nut	ZP, M8	2
25.1	510-432	Hydraulic Adapter on Pump for Connecting Hose	Straight, Hex27*45	1
25.2	730-619	O Seal Ring	Ø15*1.9	1
26	550-308	Two Stage Pump	9 gpm (13T)	1
	550-412	Two Stage Pump	11 gpm (16T)	
27	550-702	Coupling Shaft	3/4"	1
28	550-706	Coupling Spider		1
29	740-600	Set Screw	Black Oxide, M6*10	2
30	710-637	Hex Head Bolt	ZP, M8*20 (8.8)	4
31	750-834	Spring Washer	ZP, M8	4
32	750-638	Flat Washer	ZP, M8	4
33	550-814	Pump Mount	Al	1
34	710-632	Hex Head Bolt	ZP, 5/16-24*20 (8.8)	4
35	750-844	Spring Washer	Zinc, 5/16	4
36	750-617	Flat Washer	ZP, 5/16	4

REF #	PART NAME	SPECIFICATIONS	QTY PER UNIT	
37	770-123	Engine Shaft Square Key	3/16 X 1.75	1
38	960-327	Gas Engine (Kohler 6.5)		1
39	710-693	Hex Head Bolt	ZP, M8*40	4
40	750-638	Flat Washer	ZP, M8	8
41	960-429	Vibration Isolator 22/28 Ton	Ø24*Ø9*3	4
42	720-500	Lock Nut	ZP, M8	4
43	540-911	Reservoir Tank		1
44	540-328	Vented Dipstick	Ø4*83	1
45	730--655	O Seal Ring	Ø15*3.1	2
46	710-877	Oil Drain Screw	PH, M16*15	1
47	730-064	O Seal Ring	Ø20*2.4	1
48.1	540-074	Suction filter	Straight, Adapter, Hex32	1
48.2	730-602	O Seal Ring	Ø28*3.1	1
49	760-377	Hose Clamp	1"	2
50	560-315	Oil Suction Hose	Ø24*320	1
51	330-674	Fender Support		2
52	710-661	Hex Head Bolt	ZP, M8*25 (8.8)	2
53	710-637	Hex Head Bolt	ZP, M8*20 (8.8)	6
54	750-699	Flat Washer	ZP, Ø9* Ø24*1.5	2
55	750-638	Flat Washer	ZP, M8	14
56	720-500	Lock Nut	ZP, M8	8
57	330-612	Fender		2
58	330-524	Wheel	Pneumatic, 16*4.8*8 in.	2
59	720-836	Castle Nut	ZP, 1-14	2
60	760-744	Split Pin	ZP, Ø4*50	2
61	330-631	Dust Cap		2
62	320-455	Wheeled Trailer Jack		1
63	710-333	U-bolt	ZP, M10 x 190	1
64	320-457	Jack Clamp 13 Ton	W26	2
	320-459	Jack Clamp 16 Ton	W35.5	
65	710-669	Hex Head Bolt	ZP, M10*130 (8.8)	2
66	750-525	Flat Washer	ZP, M10	6
67	720-120	Lock Nut	ZP, M10	4
68	320-431	Tongue		1
69	320-437	Hitch Coupler	2"*3"	1
70	320-421	Safety Chain		2
71	710-622	Hex Head Bolt	ZP, M12*100 (8.8)	2
72	750-621	Flat Washer	ZP, M12	4
73	720-536	Lock Nut	ZP, M12	2
74	320-913	Log Tray		2
75	710-895	Inner Hex Head Bolt	Black Oxide, M8*20	8
76	750-075	Spring Washer	Black Oxide, M8	8
77	750-160	Flat Washer	Black Oxide, M8	8

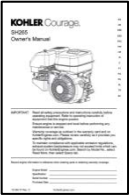
PACKING LIST

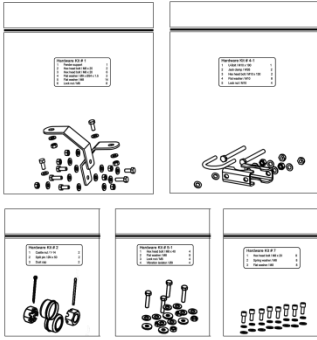
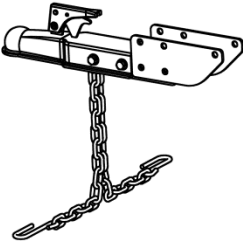
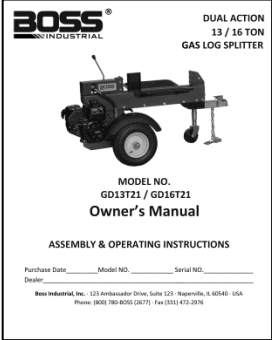
		
<p>Beam assembly x 1</p>	<p>Wheeled trailer jack assembly x 1</p>	
		
<p>Reservoir tank assembly x 1</p>	<p>Engine / Pump assembly x 1</p>	
		
<p>Log tray & Log dislodger assembly x 2</p>	<p>Hardware kits box x 1, including:</p>	
		
<p>Fender x 2</p>	<p>Control handle lever x 1</p>	<p>Engine manual x 1</p>
		
<p>Wheel x 2</p>		
		
<p>Tongue assembly x 1</p>	<p>Hardware kit #1, 2, 4, 5, 7</p>	
		<p>Instruction manual x 1</p>

WARRANTY

LIMITED WARRANTY STATEMENT

Boss Industrial, Inc., ("Boss Industrial") warrants to the original retail purchaser that this BOSS brand outdoor product is free from defect in material and workmanship and agrees to repair or replace, at Boss Industrial's, discretion, any defective product free of charge within these time periods from the date of purchase.

- Two years for all models if used for personal, family, or household use;
- 180 days for any unit used for other purposes, such as rental or commercial.

This warranty extends to the original retail purchaser only and commences on the date of the original retail purchase.

Any part of the this product manufactured or supplied by Boss Industrial and found in the reasonable judgment of Boss Industrial to be defective in material or workmanship will be repaired or replaced without charge for parts and labor by a Boss Industrial authorized service center. **How to process a warranty claim? You must first call the BOSS INDUSTRIAL service hotline 1 800 780 2677. Our technical team will guide you in trouble shooting, repairing, or returning a defective part or machine. Any unauthorized repair or return without a valid Return Authorization Number from Boss Industrial will invalidate this warranty. The expense of delivering the product to the dealer for warranty work and the expense of returning it back to the owner after repair or replacement will be paid by the owner.** Boss Industrial's responsibility in respect to claims is limited to making the required repairs or replacements and no claim of breach of warranty shall be cause for cancellation or rescission of the contract of sale of any BOSS brand product. Proof of purchase will be required by the dealer to substantiate any warranty claim. All warranty work must be performed by a Boss Industrial authorized service center.

This warranty is limited to one hundred eighty (180) days from the date of original retail purchase for any Boss Industrial brand product that is used for rental or commercial purposes, or any other income-producing purpose.

This warranty does not cover any BOSS brand product that has been subject to misuse, neglect, negligence, or accident, or that has been operated in any way contrary to the operating instructions as specified in this operator's manual. This warranty does not apply to any damage to the product that is the result of improper maintenance or to any product that has been altered or modified. The warranty does not extend to repairs made necessary by normal wear or by the use of parts or accessories which are either incompatible with the BOSS brand product or adversely affect its operation, performance, or durability. In addition, this warranty does not cover:

- A. Tune-ups – Spark Plugs, Carburetors, Adjustments, Ignition, Filters
- B. Wear items – Tires, handles, nylon liners, rubber seals, hydraulic oil, etc...
- C. Gas Engines – as they are covered under the Engine Manufacturers' Warranty.

Boss Industrial reserves the right to change or improve the design of any BOSS brand product without assuming any obligation to modify any product previously manufactured.

ALL IMPLIED WARRANTIES ARE LIMITED IN DURATION TO THE STATED WARRANTY PERIOD. ACCORDINGLY, ANY SUCH IMPLIED WARRANTIES INCLUDING MERCHANTABILITY, FITNESS FOR A PARTICULAR PURPOSE, OR OTHERWISE, ARE DISCLAIMED IN THEIR ENTIRETY AFTER THE EXPIRATION OF THE APPROPRIATE TWO-YEAR, ONE-YEAR, OR NINETY-DAY WARRANTY PERIOD. BOSS INDUSTRIAL'S OBLIGATION UNDER THIS WARRANTY IS STRICTLY AND EXCLUSIVELY LIMITED TO THE REPAIR OR REPLACEMENT OF DEFECTIVE PARTS AND BOSS INDUSTRIAL DOES NOT ASSUME OR AUTHORIZE ANYONE TO ASSUME FOR THEM ANY OTHER OBLIGATION. SOME STATES DO NOT ALLOW LIMITATIONS ON HOW LONG AN IMPLIED WARRANTY LASTS, SO THE ABOVE LIMITATION MAY NOT APPLY TO YOU. BOSS INDUSTRIAL ASSUMES NO RESPONSIBILITY FOR INCIDENTAL, CONSEQUENTIAL, OR OTHER DAMAGES INCLUDING, BUT NOT LIMITED TO, EXPENSE OF RETURNING THE PRODUCT TO AN AUTHORIZED BOSS INDUSTRIAL SERVICE CENTER AND EXPENSE OF DELIVERING IT BACK TO THE OWNER, MECHANIC'S TRAVEL TIME, TELEPHONE OR TELEGRAM CHARGES, RENTAL OF A LIKE PRODUCT DURING THE TIME WARRANTY SERVICE IS BEING PERFORMED, TRAVEL, LOSS OR DAMAGE TO PERSONAL PROPERTY, LOSS OF REVENUE, LOSS OF USE OF THE PRODUCT, LOSS OF TIME, OR INCONVENIENCE. SOME STATES DO NOT ALLOW THE EXCLUSION OR LIMITATION OF INCIDENTAL OR CONSEQUENTIAL DAMAGES, SO THE ABOVE LIMITATION OR EXCLUSION MAY NOT APPLY TO YOU.

This warranty gives you specific legal rights, and you may also have other rights which vary from state to state.

This warranty applies to all BOSS brand products manufactured by or for Boss Industrial and sold in the United States.



Boss Industrial, Inc. • 123 Ambassador Drive, Suite123 • Naperville,
IL 60540 • USA

Phone: (800) 780-BOSS (2677) • Fax (331) 472-2976

www.boss-industrial.com