

EXPLODED DIAGRAM & PARTS LIST

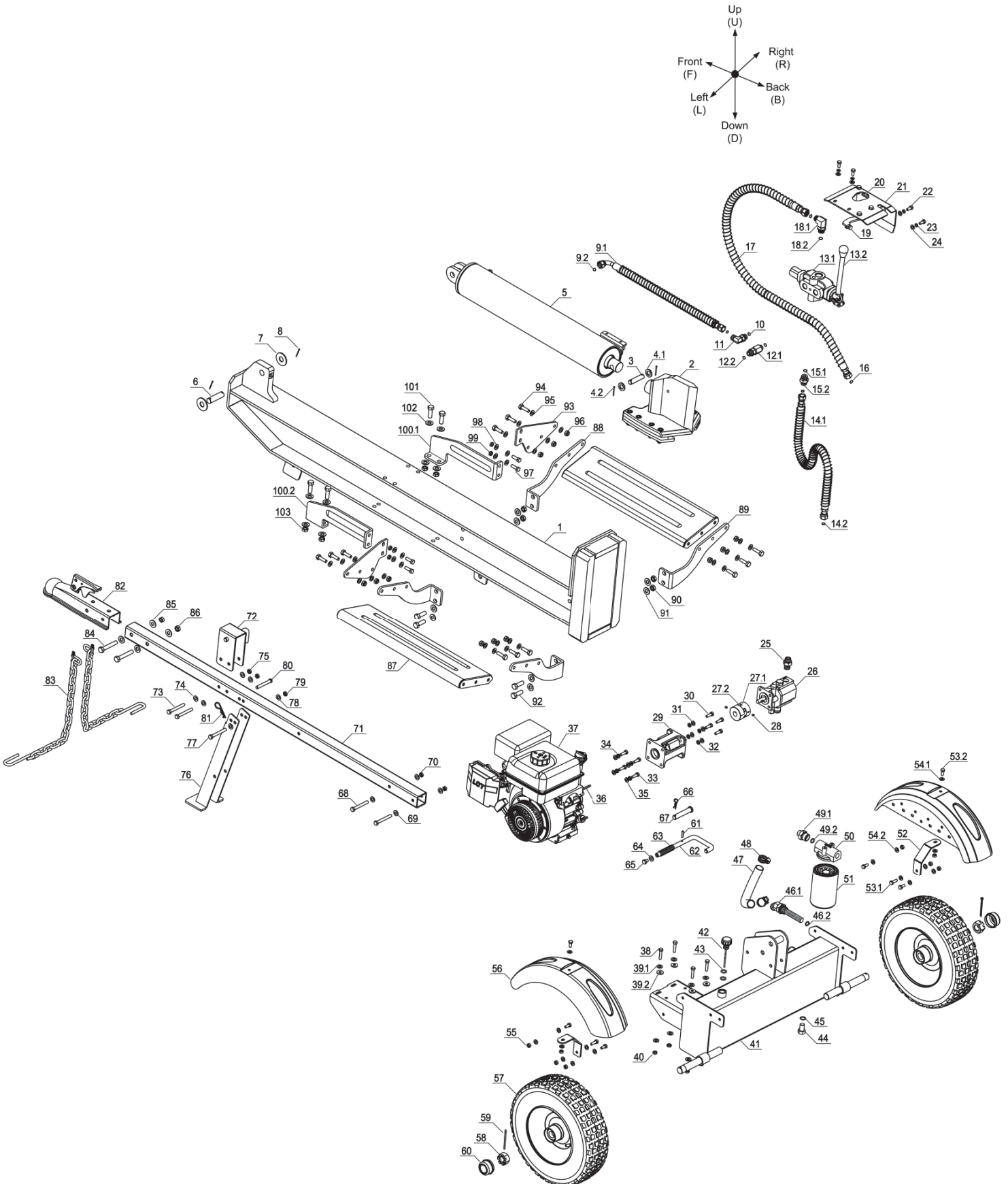





REF #	PART #	PART NAME	SPECIFICATIONS	QTY PER UNIT
1	310-632	Beam incl. End Plate 22 Ton	10-10-10/60*40*375	1
	310-387	Beam incl. End Plate 28 Ton	10-12-10/60*40*375	
	310-452	Beam incl. End Plate 34 Ton	12-12-12/60*50*375	
2	530-427	Splitting Wedge w/ Guides 22/28 Ton	Guide12	1
	530-428	Splitting Wedge w/ Guides 34 Ton	Guide14	
3	760-118	Pin	PH, Ø16*69-Ø4.5	1
4.1	750-566	Flat Washer	PH, M16	2
4.2	760-734	Split Pin	ZP, Ø4*35	2
5	530-465	Cylinder 22 Ton	4.0 in.	1
	530-479	Cylinder 28 Ton	4.5 in.	
	530-481	Cylinder 34 Ton	5.0 in.	
6	760-112	Pin	PH, Ø20*72-Ø3.5	1
7	750-423	Flat Washer	PH, M20	2
8	760-755	Split Pin	ZP, Ø3*40	2
9.1	560-422	Hydraulic Hose for A-Capacity w/ Protection Spring	1/2"*572	1
9.2	730-619	O Seal Ring	Ø15*1.9	2
10	730-077	O Seal Ring	Ø21*2.4	1
11	510-339	Hydraulic Adaptor for A-Capacity	90 Degree, Hex23, 1/2"hose	1
12.1	510-467	Hydraulic Adaptor for B-Capacity	Straight, Hex27*58	1
12.2	730-077	O Seal Ring	Ø21*2.4	2
13.1	520-799	Hydraulic Valve		1
13.2	520-452	Control Handle	Ø15*220, Ball Grip	1
14.1	560-454	Connecting Hydraulic Hose w/ Protection Spring	1/2"*900	1
14.2	730-619	O Seal Ring	Ø15*1.9	2
15.1	730-088	O Seal Ring	Ø24*2.4	1
15.2	510-448	Hydraulic Adapter on Valve for Connecting Hose	Straight, Hex27*36.5	1
16	730-661	O Seal Ring	Ø21*1.9	2
17	560--521	Oil Return Hose w/ Protection Spring	3/4*1600	1
18.1	560-462	Hydraulic Adapter	90 Degree, Hex27, 3/4"hose	1
18.2	730-088	O Seal Ring	Ø24*2.4	1
19	520-536	Handle Release Lever		1
20	520-575	Extension Spring	Ø9*99	1
21	350-226	Valve Cover		1
22	710-637	Hex Head Bolt	ZP, M8*20 (8.8)	4
23	750-834	Spring Washer	ZP, M8	4
24	750-638	Flat Washer	ZP, M8	4
25	510-432	Hydraulic Adapter on Pump for Connecting Hose	Straight, Hex27*45	1
26	550-412	Two Stage Pump	11 gpm (22/28T)	1
	550-533	Two Stage Pump	16gpm (34T)	
27.1	550-702	Coupling Shaft	3/4" (22/28T)	1
	550-703	Coupling Shaft	1" (34T)	
27.2	550-706	Coupling Spider		1
28	740-600	Set Screw	Black Oxide, M6*10	2
29	550-814	Pump Mount	Al, 22T, 28T	1
	550-817	Pump Mount	Al, 34T	
30	710-637	Hex Head Bolt	ZP, M8*20 (8.8)	4
31	750-638	Flat Washer	ZP, M8	4
32	750-834	Spring Washer	ZP, M8	4
33	710-632	Hex Head Bolt	ZP, 5/16-24*20 (8.8)	4
34	750-617	Flat Washer	ZP, 5/16	4
35	750-844	Spring Washer	Zinc, 5/16	4
36	770-123	Engine Shaft Square Key	3/16 X 1.75 (22T/28T)	1
	770-125	Engine Shaft Square Key	1/4 X 2.165 (34T)	

REF #	PART NAME	SPECIFICATIONS	QTY PER UNIT
37	960-246	Gas Engine (Subaru 5.7)	22T
	960-259	Gas Engine (Subaru 7)	28T
	960-261	Gas Engine (Subaru 9)	34T
38	710-693	Hex Head Bolt	ZP, M8*40 (22T/28T)
	710-553	Hex Head Bolt	ZP, M10*40(34T)
39.1	750-638	Flat Washer	ZP, M8 (22/28T)
	750-525	Flat Washer	ZP, M10 (34T)
39.2	960-429	Vibration Isolator 22/28 Ton	Ø24*Ø9*3
	960-430	Vibration Isolator 34 Ton	Ø24*Ø11*3
40	720-500	Lock Nut	ZP, M8 (22/28T)
	720-120	Lock Nut	ZP, M10 (34T)
41	540-911	Reservoir Tank	22/28T
	540-972	Reservoir Tank	34T
42	540-328	Vented Dipstick	Ø4*83
43	730--655	O Seal Ring	Ø15*3.1
44	710-877	Oil Drain Screw	PH, M16*15
45	730-064	O Seal Ring	Ø20*2.4
46.1	540-049	Suction filter	45 Degree Adapter, Hex32
46.2	730-122	O Seal Ring	Ø30*3.1
47	560-342	Oil Suction Hose	Ø24*300,Curved
48	760-377	Hose Clamp	1"
49.1	510-421	Hydraulic Adapter for Oil Return Hose	Straight, Hex32*43, ¾" hose
49.2	730-122	O Seal Ring	Ø30*3.1
50	540-053	Filter Cap	Al
51	540-086	Filter Screw-on	22/28T, Ø93*130
	540-089	Filter Screw-on	34T, Ø93*210
52	330-674	Fender Support	
53.1	710-661	Hex Head Bolt	ZP, M8*25 (8.8)
53.2	710-637	Hex Head Bolt	ZP, M8*20 (8.8)
54.1	750-699	Flat Washer	ZP, Ø9* Ø24*1.5
54.2	750-638	Flat Washer	ZP, M8
55	720-500	Lock Nut	ZP, M8
56	330-612	Fender	
57	330-515	Wheel	Tubeless, 16*4.8*8 in.
58	720-836	Castle Nut	ZP, 1-14
59	760-744	Split Pin	ZP, Ø4*50
60	330-631	Dust Cap	
61	760-269	Split Pin	ZP, Ø2.5*20
62	320-800	Vertical Lock Lever	ZP, Ø15*315
63	320-802	Vertical Lock Spring	ZP, Ø18*75
64	750-525	Flat Washer	ZP, M10
65	710-516	Hex Head Bolt	ZP, M10*20 (8.8)
66	760-688	Spring Clip	ZP, Ø2.5
67	760-157	Clevis Pin	PH, Ø16*85
68	710-580	Hex Head Bolt	ZP, M10*75 (8.8)
69	750-525	Flat Washer	ZP, M10
70	720-120	Lock Nut	ZP, M10
71	320-427	Tongue	50*50*3*1570
72	320-843	Horizontal Beam Lock	
73	710-568	Hex Head Bolt	ZP, M10*70 (8.8)
74	750-525	Flat Washer	ZP, M10
75	720-120	Lock Nut	ZP, M10
76	320-476	Jack Stand	

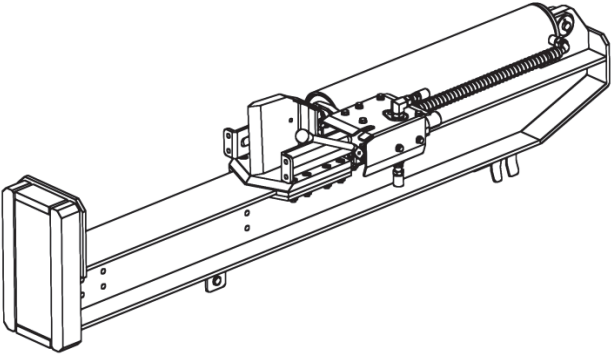
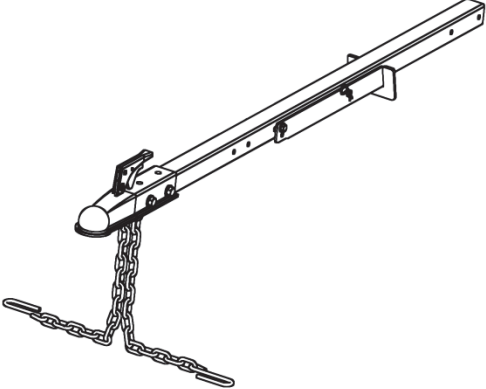
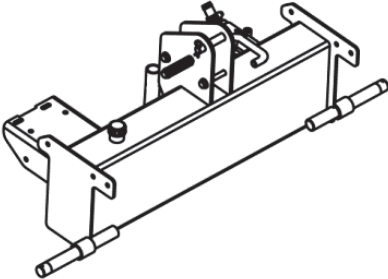
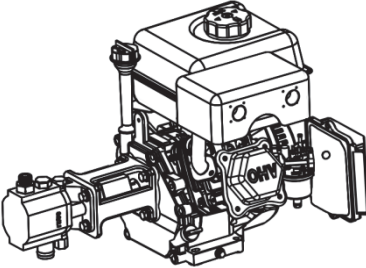
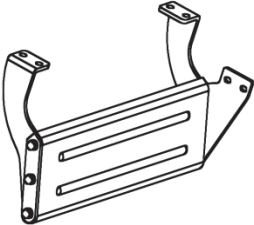
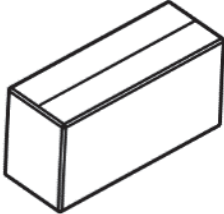
REF #	PART #	PART NAME	SPECIFICATIONS	QTY PER UNIT
77	710-580	Hex Head Bolt	ZP, M10*75 (8.8)	1
78	750-525	Flat Washer	ZP, M10	2
79	720-120	Lock Nut	ZP, M10	1
80	760-152	Clevis Pin	PH, Ø10*70	1
81	760-679	Spring Clip	ZP, Ø3	1
82	320-420	Hitch Coupler	2"*2"	1
83	320-421	Safety Chain		2
84	710-433	Hex Head Bolt	ZP, M12*75 (8.8)	2
85	750-621	Flat Washer	ZP, M12	4
86	720-536	Lock Nut	ZP, M12	2
87	320-938	Log Tray Plate		2
88	320-930	Log Tray Frame (FR, BL)		2
89	320-931	Log Tray Frame (FL, BR)		2
90	720-536	Lock Nut	ZP, M12	4
91	750-621	Flat Washer	ZP, M12	8
92	710-511	Hex Head Bolt	ZP, M12*45 (8.8)	4
93	320-925	Log Dislodger		2
94	710-518	Hex Head Bolt	ZP, M10*30 (8.8)	12
95	750-525	Flat Washer	ZP, M10	24
96	720-120	Lock Nut	ZP, M10	12
97	710-520	Hex Head Bolt	ZP, M10*25 (8.8)	4
98	750-525	Flat Washer	ZP, M10	8
99	720-120	Lock Nut	ZP, M10	4
100.1	320-929	Dislodger Support R		1
100.2	320-928	Dislodger Support L		1
101	710-438	Hex Head Bolt	ZP, M12*35	4
102	750-621	Flat Washer	ZP, M12	8
103	720-536	Lock Nut	ZP, M12	4

PACKING LIST

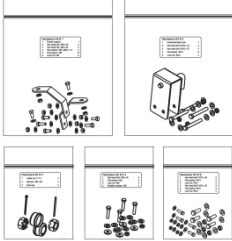
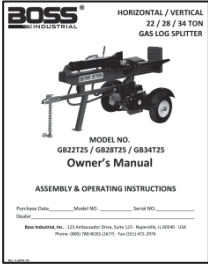
		
<p>Beam assembly x 1</p>	<p>Tongue assembly x 1</p>	
		
<p>Reservoir tank assembly x 1</p>	<p>Engine / Pump assembly x 1</p>	
		
<p>Log tray & Log dislodger assembly x 2</p>	<p>Hardware kit box x 1, including:</p>	
		
<p>Fender x 2</p>	<p>Filter screw-on x 1</p>	<p>Engine manual x 1</p>
		
<p>Wheel x 2</p>	<p>Hardware kit #1, 2, 3, 5, 6</p>	<p>Instruction manual x 1</p>