



HORIZONTAL ELECTRIC DUAL ACTION 8 TON LOG SPLITTER



**MODEL NO.
ED8T20**

Owner's Manual

ASSEMBLY & OPERATING INSTRUCTIONS

Purchase Date _____ Serial No. _____

Dealer _____

Boss Industrial, Inc. • 1864 High Grove Lane, Unit 116 • Naperville, IL 60540 • USA

Phone: (800) 780-BOSS (2677) • Fax (331) 472-2976

www.boss-industrial.com

Table of Contents

| | Page(s) |
|-------------------------------------|---------|
| Important Safety Information | 1-6 |
| Intended Use | 1 |
| Personal Protective Equipment | 1 |
| Safety Decals | 1-4 |
| Electrical Safety | 5 |
| Log Splitter Overview | 6 |
| General Safety | 7 |
| Work Area | 8 |
| Operation of the Log Splitter | 8 |
| Maintenance Safety | 9 |
| Hydraulic Safety | 10 |
| Fire Prevention | 10 |
| Assembly Instructions | 11-12 |
| Pre-Operation Instructions | 12 |
| Operating Instructions | 13-14 |
| Transportation | 14 |
| Storage | 14 |
| Maintenance | 15-16 |
| Troubleshooting | 17 |
| Technical Specifications | 18 |
| Exploded Diagram & Parts List | 19-21 |
| Warranty Information | 22 |
| Packing List | 23 |



IMPORTANT SAFETY INFORMATION



WARNING: Read and thoroughly understand all instructions and safety information before assembling or operating this log splitter. Failure to do so may cause serious injury or death. Do not allow anyone to operate this log splitter who has not read this manual. As with all power equipment, a log splitter can be dangerous if assembled or used improperly. Do not operate this log splitter if you have doubts or questions concerning safe operation. Call our customer service department at 1-800-780-2677 to address these concerns.

Si no entiende ingles, se prefiere que busque alguien que interprete las instrucciones para usted.



This safety alert symbol identifies important safety messages in this manual. Failure to follow this important safety information may result in serious injury or death.

INTENDED USE

NEVER use this log splitter for any purpose other than **splitting wood**. It is designed for this use **only**. Any other use can cause serious injury or death.

PROTECTIVE EQUIPMENT

BEFORE operating this log splitter make sure that you wear safety gear such as goggles or safety glasses, steel toed shoes and tight fitting gloves (without loose cuffs or draw strings). Always wear a protective hearing device when operating this log splitter.

NEVER wear loose clothing or jewelry that can be caught by moving parts of the log splitter. Keep clothing and hair away from all moving parts when operating this log splitter.

SAFETY DECALS

Make sure that all safety warning decals are in good condition and readable. Always replace missing or defaced decals. Contact Boss Industrial, Inc. at 1-800-780-2677 for replacement decals.



IMPORTANT SAFETY INFORMATION

8 Ton Dual Action Log Splitter

CAUTION!

- Read and understand safety and operating instructions in owner's manual completely. Failure to do so may result in serious injury or death.
- Always wear safety glasses, safety shoes, protective hearing devices, and tight fitting gloves during operation.
- Set up log splitter on clear, level, dry and solid ground. Keep off slopes and slippery surfaces. Always block the wheels.
- No one under the age of 18 should operate log splitter.
- Only one person is permitted to load logs and operate controls. Keep bystanders, children, pets and helpers at least 25 ft. away.
- Always stay in operator zone specified by manufacturer during operation.
- Keep work area clear of split wood, debris, and other obstacles.
- Do not leave motor running unattended.
- Only split wood in the direction of the grain.



LEFT NEUTRAL RIGHT

OPERATING INSTRUCTIONS

- Read and understand safety and operating instructions in owner's manual completely.
- Start the motor.
- Grab the sides of the log to load it onto the rail, aligning it against the end wedge.
- If necessary, stabilize the log by holding its sides, NEVER by the ends or the top.
- Move the control handle to the RIGHT position to extend the cylinder, driving the ram against the log to the end wedge.
- Release the control handle to STOP the ram.
- Move the control handle to the LEFT position to retract the cylinder and split a log on the other side.

WARNING!



- Do not operate log splitter under the influence of alcohol or drugs.
- Keep hands, feet, and all body parts away from end wedge, pushing ram, partially split wood, and moving parts.
- Do not stand on or reach over log splitter.
- Do not refill hydraulic oil while the motor and pump are hot or running.
- Never check for leaks with your hands during operation. High pressure fluid can escape from small holes and cause serious injury by puncturing skin which could result in blood poisoning.
- Do not split wood larger than recommended capacity.
- Do not force the log splitter. It is already designed to operate at its maximum speed and tonnage. If you experience especially hard wood, DO NOT continue to push on controls for over 5 seconds.
- Do not attempt to remove split logs until the ram completes its cycle.
- NEVER use your hands to remove a jammed log.

Motor YY80AL-2

115V AC, 60 Hz, 2 HP, 13.5 A
3400r/min, IP54, INCL: B

WARNING!



Do NOT expose to rain or use in damp locations!



Only use a 3-prong grounding plug and a 3-pole outlet!



When using an extension cord, ensure that it uses a 3-prong plug.



Check that the switch, cable, and plug are not damaged before each use to avoid electric shock or short circuit.

CAUTION!

Never tamper with the motor or run it at excessive speeds.

Always unplug from power source while repairing or adjusting the log splitter.

Never overload the motor. The motor could overheat, blow a fuse, or trip a circuit breaker.

Do NOT leave the motor running unattended.



BOSS INDUSTRIAL 8 Ton Log Splitter ED8T20

Motor: 115V, 60 Hz, 2 HP, 13.5A
 Max. splitting force: 8 Ton
 Max. splitting length: 20.5 inch
 Max. splitting diameter: 10.5 inch
 Net weight: 160 lbs
 Serial NO.: HE38RRL-001







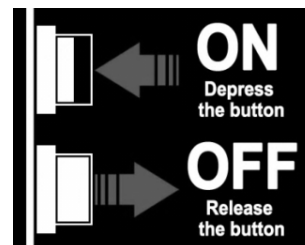







Boss Industrial, Inc.



1864 High Grove Lane, Unit 116, Naperville, IL 60540
 www.boss-industrial.com, 1-800-780-2677



Some of the following symbols may be used on this tool. Please study them and learn their meaning. Proper interpretation of these symbols will allow you to operate the tool better and safer.

| SYMBOL | NAME | DESIGNATION/EXPLANATION |
|---|-------------------------------|---|
| V | Volts | Voltage |
| A | Amperes | Current |
| Hz | Hertz | Frequency (cycles per second) |
| W | Watt | Power |
| min | Minutes | Time |
| ~ | Alternating Current | Type of current |
| = | Direct Current | Type or a characteristic of current |
| n_0 | No Load Speed | Rotational speed, at no load |
|  | Class II Construction | Double-insulated construction |
| .../min | Per Minute | Revolutions, strokes, surface speed, orbits etc., per minute |
|  | Wet Conditions Alert | Do not expose to rain or use in damp locations. |
|  | Read The Operator's Manual | To reduce the risk of injury, user must read and understand operator's manual before using this product. |
|  | Eye, Face & Ear Protection | Always wear safety goggles or safety glasses with side shields, earplugs and a face shield when operating this product. |
|  | Safety Alert | Precautions that involve your safety. |
|  | Wear Gloves | Always wear nonslip, heavy-duty protective gloves when operating this product. |
|  | Wear Safety Footwear | Always wear nonslip safety footwear when operating this product. |
|  | Keep Bystanders Away | Always keep bystanders at least 25 ft. (7.5 m) away. |
|  | Keep Hands Away | Always keep hands away from the wedge and the ram. |
|  | Pinch Point | Never touch the cylinder bed, ram, or wedge during machine operation. |
|  | Rotating & Moving Parts Alert | Beware of rotating and moving parts, serious injury could occur. |
|  | Electric Shock Alert | Never touch damaged or exposed wires while the machine is connected to a power source. |

The following signal words and meanings are intended to explain the levels of risk associated with this product.

| SYMBOL | SIGNAL | MEANING |
|---|-----------------|--|
|  | DANGER: | Indicates an imminently hazardous situation, which, if not avoided, will result in death or serious injury. |
|  | WARNING: | Indicates a potentially hazardous situation, which, if not avoided, could result in death or serious injury. |
|  | CAUTION: | Indicates a potentially hazardous situation, which, if not avoided, may result in minor or moderate injury. |
| | CAUTION: | (Without Safety Alert Symbol) Indicates a situation that may result in property damage. |

SERVICE & REPAIR

Servicing requires extreme care and knowledge and should be performed only by a qualified service technician. For service we suggest you return the product to your nearest **AUTHORIZED SERVICE CENTER** for repair. When servicing, use only identical replacement parts.

WARNING:

To avoid serious personal injury, do not attempt to use this product until you read thoroughly and understand completely the operator's manual. If you do not understand the warnings and instructions in the operator's manual, do not use this product. Call Boss Industrial customer service for assistance.

WARNING:



The operation of any power tool can result in foreign objects being thrown into your eyes, which can result in severe eye damage. Before beginning power tool operation, always wear safety goggles or safety glasses with side shields and, when needed, wear a full face shield and earplugs. We recommend a Wide Vision Safety Mask for use over eyeglasses or standard safety glasses with side shields. Always use eye protection which is marked to comply with ANSI Z87.1.

SAVE THESE INSTRUCTIONS

ELECTRICAL SAFETY

EXTENSION CORDS

Use only 3-wire extension cords that have 3-prong grounding plugs and 3-pole receptacles that accept the tool's plug. When using a power tool at a considerable distance from the power source, use an extension cord heavy enough to carry the current that the tool will draw. An undersized extension cord will cause a drop in line voltage, resulting in a loss of power and causing the motor to overheat. Use the chart provided below to determine the minimum wire size required in an extension cord. Only round jacketed cords listed by Underwriter's Laboratories (UL) should be used.

**Ampere rating (on tool faceplate)

| Cord Length | Wire Size (A.W.G.) | | | | | |
|-------------|--------------------|---------|---------|---------|----------|-----------|
| | 0-2.0 | 2.1-3.4 | 3.5-5.0 | 5.1-7.0 | 7.1-12.0 | 12.1-16.0 |
| 25' | 16 | 16 | 16 | 16 | 14 | 14 |
| 50' | 16 | 16 | 16 | 14 | 14 | 12 |
| 100' | 16 | 16 | 14 | 12 | 10 | — |

**Used on 12 gauge - 20 amp circuit.

NOTE: AWG = American Wire Gauge

When working with the tool outdoors, use an extension cord that is designed for outside use. This is indicated by the letters "WA" on the cord's jacket.

Before using an extension cord, inspect it for loose or exposed wires and cut or worn insulation.

WARNING:

Keep the extension cord clear of the working area. Position the cord so that it will not get caught on lumber, tools or other obstructions while you are working with a power tool. Failure to do so can result in serious personal injury.

WARNING:

Check extension cords before each use. If damaged replace immediately. Never use tool with a damaged cord since touching the damaged area could cause electrical shock resulting in serious injury.

ELECTRICAL CONNECTION

This tool is powered by a precision built electric motor. It should be connected to a **power supply that is 115 volts, 60 Hz, AC only (normal household current)**. Do not operate this tool on direct current (DC). A substantial voltage drop will cause a loss of power and the motor will overheat. If the product does not operate when plugged into an outlet, double check the power supply.

SPEED AND WIRING

The speed is not constant and decreases under a load or with lower voltage. For voltage, the wiring in a shop is as important as the motor's horsepower rating. A line intended only for lights cannot properly carry a power tool motor. Wire that is heavy enough for a short distance will be too light for a greater distance. A line that can support one power tool may not be able to support two or three tools.

GROUNDING INSTRUCTIONS

In the event of a malfunction or breakdown, grounding provides a path of least resistance for electric current to reduce the risk of electric shock. This tool is equipped with an electric cord having an equipment-grounding conductor and a grounding plug. The plug must be plugged into a matching outlet that is properly installed and grounded in accordance with all local codes and ordinances.

Do not modify the plug provided. If it will not fit the outlet, have the proper outlet installed by a qualified electrician. Improper connection of the equipment-grounding conductor can result in a risk of electric shock. The conductor with insulation having an outer surface that is green with or with-out yellow stripes is the equipment-grounding conductor. If repair or replacement of the electric cord or plug is necessary, do not connect the equipment-grounding conductor to a live terminal.

Check with a qualified electrician or service personnel if the grounding instructions are not completely understood, or if in doubt as to whether the tool is properly grounded.

Repair or replace a damaged or worn cord immediately. This tool is intended for use on a circuit that has an outlet like the one shown below. Ensure that the outlet has a grounding pin.

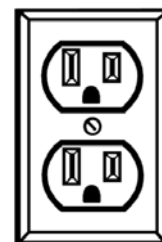

LOG SPLITTER OVERVIEW

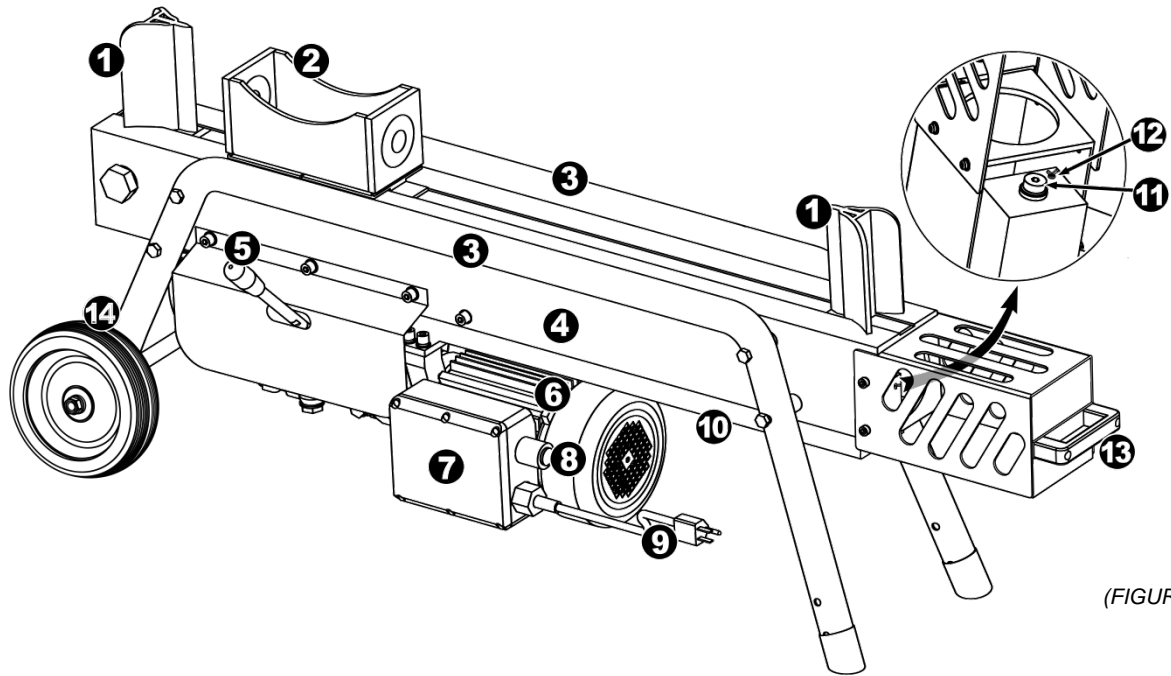

(FIGURE 1).

- 1. End wedge
- 2. Sliding ram
- 3. Support legs, log holder
- 4. Machine body
- 5. Control handle
- 6. 115v motor
- 7. Motor control box
- 8. On/Off switch
- 9. Electrical cable with plug
- 10. Oil reservoir
- 11. Oil drain bolt with dipstick
- 12. Vent plug
- 13. Towing handle
- 14. Wheel



IMPORTANT SAFETY INFORMATION

GENERAL SAFETY

Failure to follow these instructions may result in serious injury or death.

ALWAYS read the operator's manual before operation.

NEVER allow children to operate this log splitter. **NEVER** allow adults lacking proper instructions and understanding to operate this log splitter.

KEEP all people and pets a minimum of 25 feet away from your work area when operating this log splitter. Only the operator is to be near the log splitter during use.

ALWAYS wear safety glasses.

NEVER activate the control until all people are clear of the work area.

NEVER use in an explosive atmosphere.

GUARD against electrical shock by preventing body contact with grounded surfaces. For example: pipes, radiators, ranges, refrigerator enclosures.

KEEP guards in place and in good working order.

USE the proper extension cord. Make sure your extension cord is in good condition.

NEVER operate the log splitter when under the influence of alcohol, drugs or medication.

NEVER allow a person who is tired or otherwise not alert to operate the log splitter.

USE only an electrical circuit having adequate capacity as recommended by the log splitter manufacturer.

“BLOWING” a fuse or tripping a circuit breaker is usually a warning that you are overloading the machine or have too many devices taking power from the circuit, or both. Do NOT install a higher capacity fuse!

WORK AREA

NEVER operate the log splitter on slippery, wet, muddy or icy ground.

ONLY operate your log splitter on level ground. Operating on a slope could cause the log splitter to roll over or logs to fall off.

NEVER attempt to move your log splitter over hilly or uneven terrain.

ALWAYS block the wheels to prevent movement of the log splitter while in operation.

NEVER leave tools or pieces of wood on the tool while it is in operation.

ONLY operate your log splitter in daylight or under good artificial light.

ALWAYS keep the work area clean. Remove split wood around your log splitter immediately so that you don't stumble over it.

OPERATOR ZONE

ONLY operate the log splitter from the operator zone as shown in the diagram. The operator has the safest and most efficient access to the control valve and the beam in this location. Failure to operate the log splitter in this position can result in serious injury or death.

(FIGURE 2).

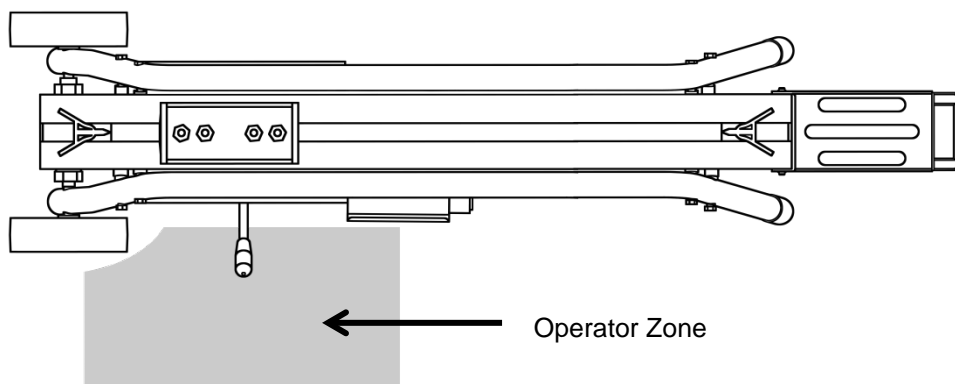



IMPORTANT SAFETY INFORMATION

KNOW how to stop the log splitter and disengage the controls before operating it.

NEVER place hands or feet between the log and splitting wedge during forward or reverse stroke. Serious injury or death could result.

NEVER straddle or step over the log splitter during operation. **NEVER** reach or bend over the log splitter to pick up a log. **NEVER** try to split two logs on top of each other.

NEVER try to cross split a log.

NEVER attempt to load your log splitter when the ram or wedge is in motion.

ALWAYS use your hand to operate the control lever on the valve. **NEVER** use your foot, a rope or any extension device.

NEVER move the log splitter while the motor is running. Shut off the motor even if you are leaving the log splitter for a short period of time.

MAINTENANCE SAFETY

NEVER operate your log splitter when it is in poor mechanical condition or in need of repair. Periodically check that all nuts, bolts, screws, hydraulic fittings and hose clamps are tight.

NEVER alter your log splitter in any manner under any circumstances. Such alterations may cause your log splitter to be unsafe and will void the warranty.

ALWAYS unplug from the power source while repairing or adjusting the splitter.

Perform all recommended maintenance procedures before using your log splitter. Replace all damaged or worn parts immediately.

NEVER tamper with the motor to run it at excessive speeds. The maximum motor speed is preset by the manufacturer and is within safety limits.

ALWAYS check the level of hydraulic oil before operation.

ALL replacement parts must meet manufacturer's specifications.



IMPORTANT SAFETY INFORMATION

HYDRAULIC SAFETY

The hydraulic system of your log splitter requires careful inspection along with the mechanical parts. Be sure to replace frayed, kinked, cracked or otherwise damaged hydraulic hoses or hydraulic components.

NEVER check for leaks of hydraulic fluid with your hand. Fluid escaping from a small hole can be almost invisible. Escaping fluid under pressure can have sufficient force to penetrate skin causing serious personal injury or even death. Leaks can be detected by passing a piece of cardboard over the suspected leak and looking for discoloration.

ALWAYS seek professional medical attention immediately if injured by escaping hydraulic fluid. Serious infection or reaction can develop if proper medical treatment is not administered immediately.

ALWAYS be sure to relieve all pressure by shutting off the motor and moving the control handle back to stop position.

NEVER remove the vent plug from the hydraulic tank or reservoir while the log splitter is running. The tank could contain hot oil under pressure which could result in serious injury.

NEVER adjust the hydraulic valve. The pressure relief valve on your log splitter is preset at the factory. Only a qualified service technician should perform this adjustment.

FIRE PREVENTION

NEVER operate your log splitter near a flame or spark. Hydraulic oil is flammable and can explode.

NEVER smoke while operating or refueling your log splitter. Gas fumes can easily explode.

ALWAYS take a Class B fire extinguisher with you when operating this log splitter in dry areas as a precautionary measure against possible flying sparks.



IMPORTANT SAFETY INFORMATION

UNPACKING & ASSEMBLY

This product has been shipped pre-assembled.

- Carefully remove the log splitter and all accessories from the box. Make sure that all items listed in the packing list are included.
- Inspect the tool carefully to make sure no breakage or damage occurred during shipping.
- Do not discard packing materials until you have carefully inspected and satisfactorily operated the tool.
- If any parts are damaged or missing, please call 1-800-780-2677 for assistance.
- Screw the control handle lever into handle bracket, and attach safety shield before operation (see *FIGURE 3*).

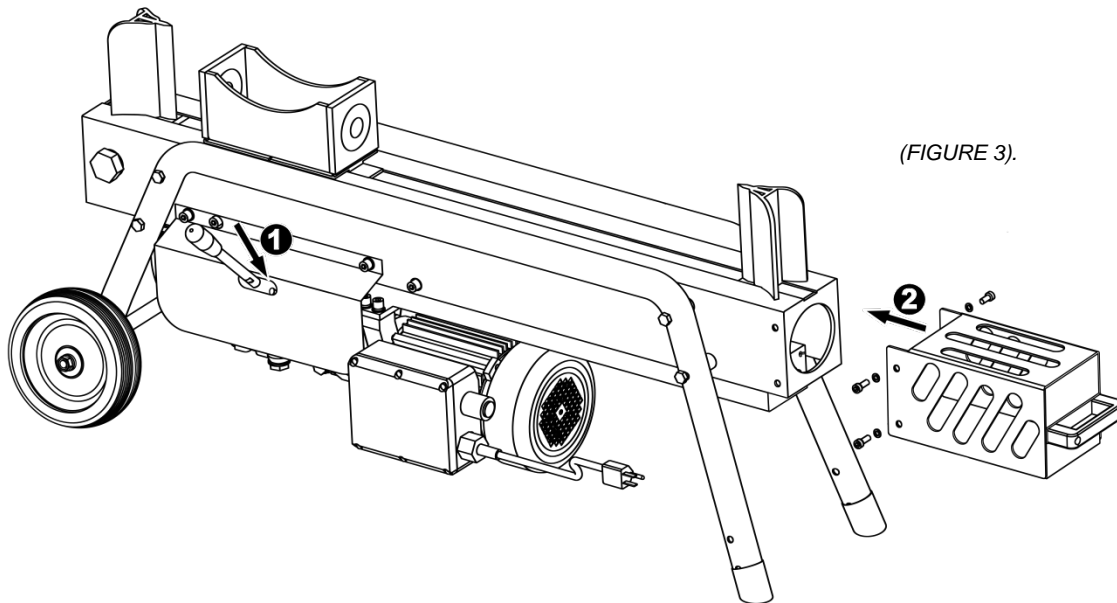

WARNING:

If any parts are damaged or missing, do not operate this tool until the missing parts are replaced. Failure to do so could result in possible serious personal injury.

WARNING:

Do not attempt to modify this tool or create accessories not recommended for use with this tool. Any such alteration or modification is misuse and could result in a hazardous condition leading to possible serious personal injury.

WARNING:

Do not connect to power supply until assembly is complete. Failure to comply could result in accidental starting and possible serious personal injury.

PRE-OPERATION INSTRUCTIONS

! WARNING:

Do not allow familiarity with tools to make you careless. Remember that a careless fraction of a second is sufficient to inflict serious injury.

! WARNING:

Always wear safety goggles or safety glasses with side shields when operating this tool. Failure to do so could result in objects being thrown into your eyes resulting in possible serious injury.

! WARNING:

Do not use any attachments or accessories not recommended by the manufacturer of this tool. The use of attachments or accessories not recommended can result in serious personal injury.

BEFORE USING THE LOG SPLITTER

- Always block the wheels to prevent movement of the log splitter while in operation.
- Clear the work area.
- Check that all nuts, bolts and hydraulic fittings are tight to be sure the equipment is in a safe working condition.
- Make sure your outlet type, voltage, and frequency match the data stated on the model plate (or “Technical Specifications” in this manual).
- Check that the switch, power cable and plug are not damaged (no cracks, etc.) to prevent the risk of electric shock or a short circuit.
- Wear non-slip safety shoes, safety goggles, safety gloves protective hair covering and suitable work clothing. Never wear jewelry, necktie and other loose clothing.

Loosen the hydraulic vent plug to release any trapped air that may have accumulated during shipping. Operate the log splitter for several cycles to repel the air. Do not move the splitter while the vent plug is loosened as the hydraulic fluid could spill out.

NOTE: Failure to loosen the hydraulic vent prior to operation of this product may cause abnormal splitting or the seals in the hydraulic system to blow out. Blown seals could cause permanent damage to the log splitter.

Log preparation: Logs should be cut with square ends. Never split logs larger than 10.5 in. diameter or 20-1/2 in. long. Uneven logs (e.g. knotted, curved, etc.) should not be used.

Oil the wedge and upper side of the machine body. This will allow the log to move smoothly on the surface (see highlighted parts on *FIGURE 4*).

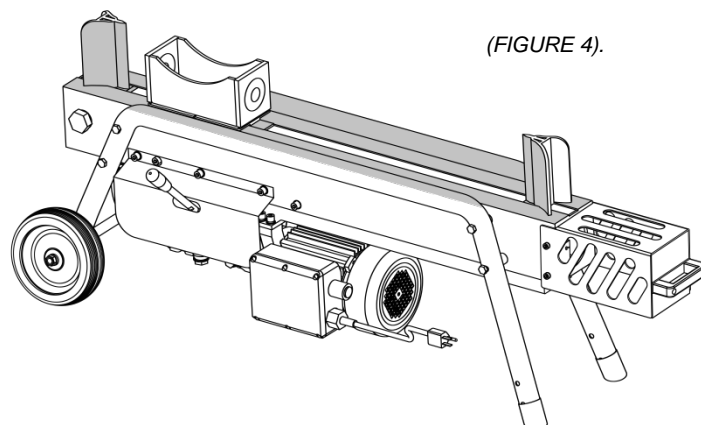

Always check the oil level **before** you start the log splitter.

To check the oil level:

- Unplug the log splitter.
- Using the lift handle, stand the log splitter on the end with the wheels (see *FIGURE 8*).
- Using a 6mm hex key, remove the oil drain bolt.
- Wipe the dipstick clean then reinsert it back into the oil tank.
- Remove the dipstick and check to see if the oil level is between the first and second groove on the dipstick (see *FIGURE 7*).
- If there is not enough oil in the oil tank, add oil until the proper level is reached.
- If there is the proper amount of oil in the oil tank, wipe the dipstick clean then replace it in the oil tank and tighten the oil drain bolt securely.

NOTE: See “Replacing Hydraulic Oil” in the *Maintenance* section for recommended oil type.

OPERATING INSTRUCTIONS

1. Plug the unit into a 3 prong outlet.
2. Press the power button to turn the log splitter on.
3. Place the log firmly against one of the wedges.
4. Move control handle to the left or right to split the log. Release the handle to stop the ram at desired position and begin loading the next log.
5. When the machine is no longer in use, switch off and unplug the power cable.

NOTE:

- a) Ensure that the horizontal distance between the splitter and outlet is more than 5 feet.
- b) Load each log by grasping the rounded sides of the log only.
- c) Only allow responsible adults who have read and understand the manual to operate this machine.
- d) Be familiar with all controls and proper operation. Know how to stop the machine quickly in the event of an emergency.
- e) Do not operate the machine while under the influence of alcohol, drugs or medication.
- f) Only a single operator is allowed to load and operate this log splitter. Keep bystanders, helpers, pets and children a sufficient distance, at least 25 feet from the machine.
- g) Only use your hands to operate the control handle and the switch. Arms, feet, knees, rope, heavy objects and extension device are not allowed.
- h) Never put any part of your body between the extending ram and the wedge.
- i) Don't step over the log splitter when the motor is running.
- j) Always split log along its grain. If it is cut against the grain, there is potential for the wood to burst or fly out resulting in injury.
- k) **Don't force the tool. It is already designed to operate at its maximum speed and tonnage. If you experienced problems splitting especially hard wood, do not continue to push on the control handle for more than 3 seconds. Release the control handle at once to avoid damage. If the motor stops, turn off the motor and then turn it back on again to continue operation.**
- l) If the log is clipped or jammed on the wedge, release the control handle and unplug the power cable immediately. Gently knock off the log with a hammer or mallet (not with your hands).
- m) Never attempt to split more than one log at a time unless the ram has fully extended and a second log is needed to complete the separation of the first log. Never attempt to split one log on top of another.
- n) Regularly clear the split wood to keep the work area clear of debris.
- o) Periodically check that all nuts, bolts, screws, hydraulic fittings and hose clamps are tightened.
- p) Never operate your splitter on wet, muddy or icy surfaces. Safe footing is essential in preventing accidents.
- q) Never leave the machine unattended while the motor is running.
- r) **Never use this machine in a damp or rainy environment.**
- s) Only operate the log splitter when there is sufficient lighting.
- t) Never tamper with the motor to run it at excessive speeds. The maximum motor speed is preset by the manufacturer and is within safety limits.
- u) Switch off and unplug the power cable if the machine malfunctions. For example: if the machine makes loud noises and the ram is running erratically, there is a strong possibility that there is excessive air in the hydraulic lines or there is a shortage of hydraulic oil in the tank (refer to the Troubleshooting section for the solution).
- v) Do not pull on the power supply cable to unplug the machine.

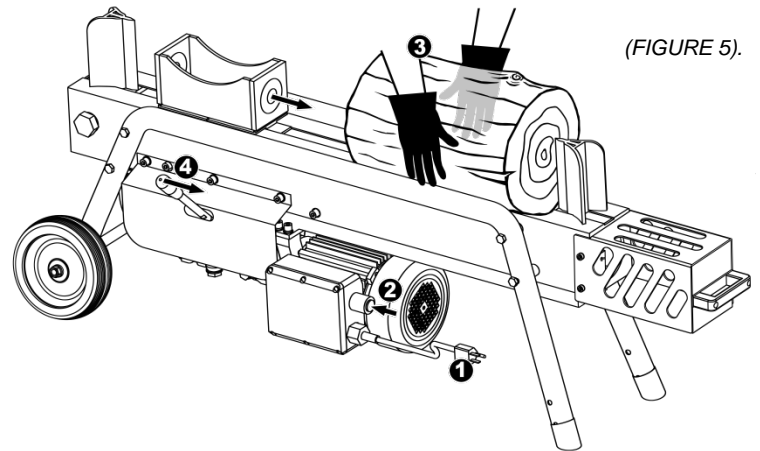

SPLITTING LOGS

See *FIGURE 5*.

Always place logs lengthwise on the work table and resting firmly on the side supports with one end against the wedge. Place logs flat and in the direction of the grain. Never angle the log to split it or place the log crosswise on the splitter. Never split more than one log at a time.

- Place log lengthwise and lying flat on the work table.
- Both ends of the log should be cut as square as possible to help prevent the log from riding out of the splitter during operation.
- **Do not split logs greater than 20.5 inches in length.**

NOTE: If the log is small, place it against the wedge before starting the splitter.



WARNING:

Never keep pressure on the wood by trying to force the log splitter for more than **three** seconds. After three seconds, the oil will heat up and could damage the tool.

TRANSPORTATION

- This machine can fit in most vehicles for transportation.
- Ensure that the splitter is properly secured before the vehicle is in motion.
- Ensure vent plug is tightened, and that all hydraulic fittings are tight to avoid leaking oil.

NOTE:

- a) Never move this machine while the motor is running.
- b) Be extra cautious when moving this machine on rugged and rough terrain.
- c) Store the machine upright so and ensure that it cannot be tipped over during transport.
- d) Never allow anyone to ride on the machine while transporting.

STORAGE

NOTE:

- a) Store this unit switched off and unplugged.
- b) Allow machine to cool 5 minutes after every use before storing.
- c) Protect power supply cable from heat, sunshine, aggressive liquids and sharp edges.
- d) Store unit in a clean, dry area. Do not store in unprotected areas outdoors.
Never place near corrosive materials or in a damp environment.
- e) Do not allow children near the splitter.

MAINTENANCE

WARNING:

When servicing, use only identical replacement parts. Use of any other parts may create a hazard or cause product damage.

WARNING:

Only the parts shown on the parts list are intended to be repaired or replaced by the customer. All other parts should be replaced at an Authorized Service Center.

GENERAL MAINTENANCE

Avoid using solvents when cleaning plastic parts. Most plastics are susceptible to damage from various types of commercial solvents and may be damaged by their use. Use clean wipes to remove dirt, dust, lubricant, grease, etc.

WARNING:

Do not at any time let brake fluids, gasoline, petroleum-based products, penetrating lubricants, etc., come in contact with plastic parts. Chemicals can damage, weaken or destroy plastic which may result in serious personal injury.

SHARPENING THE WEDGE

After using the log splitter for some time, it may be necessary to sharpen the wedge. Using a fine-toothed file, smooth any burrs or crushed areas along the cutting edge.

LUBRICATION

All of the bearings in this tool are lubricated with a sufficient amount of high grade lubricant for the life of the unit under normal operating conditions. Therefore, no further lubrication is required on the bearings.

REPLACING HYDRAULIC OIL

See *FIGURES 6, 7, 8, 9.*

The hydraulic oil in the log splitter should be changed every 100 hours of use.

- Unplug the log splitter.
- Position the log splitter so that the oil drain bolt is positioned lower than the opposite side of the machine. Ensure that the log splitter is tilted to an angle of at least 30 degrees. The log splitter should be placed securely.
- Using a 6mm hex key, remove the oil drain bolt and disconnect the vent plug.
- Drain the hydraulic oil from the oil tank into a four liter capacity container.
- Once the oil has drained from the oil tank, turn the log splitter on the end with the wheels.
- Refill the oil tank with fresh hydraulic oil (3 liters or 3.2 quarts).
- Place the cleaned dipstick into the oil tank. Remove and check the oil level.
- Start the motor and cycle the ram several times to remove excess air from the reservoir.

NOTE: The oil level should be between the two grooves around the bottom of the dipstick as shown in *FIGURE 7.*

- **Use AW32 hydraulic fluid.**
- Replace oil drain bolt. Tighten securely.
- Dispose old oil at an oil recycling center.

FIGURE 6.

Drain Oil from Reservoir

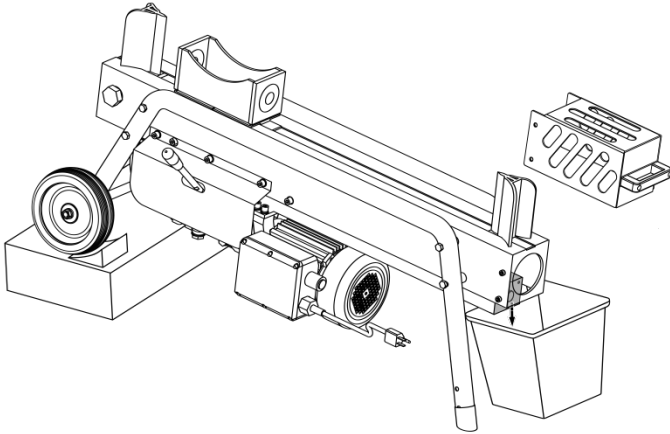

FIGURE 7.

Note Acceptable Oil Fill Level

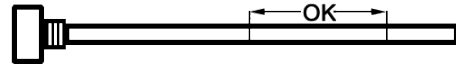

FIGURE 8.

Place Log Splitter In Vertical Position

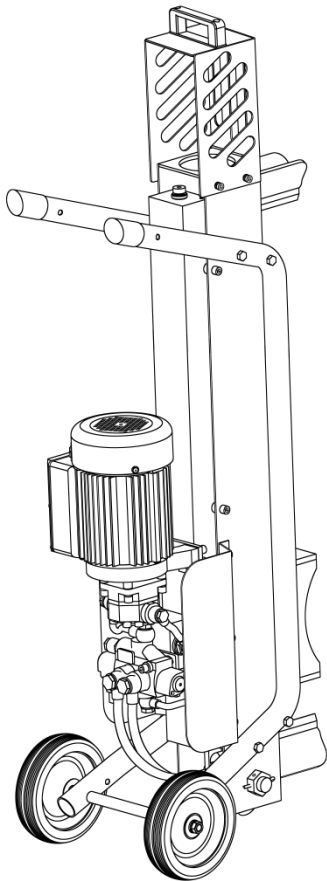
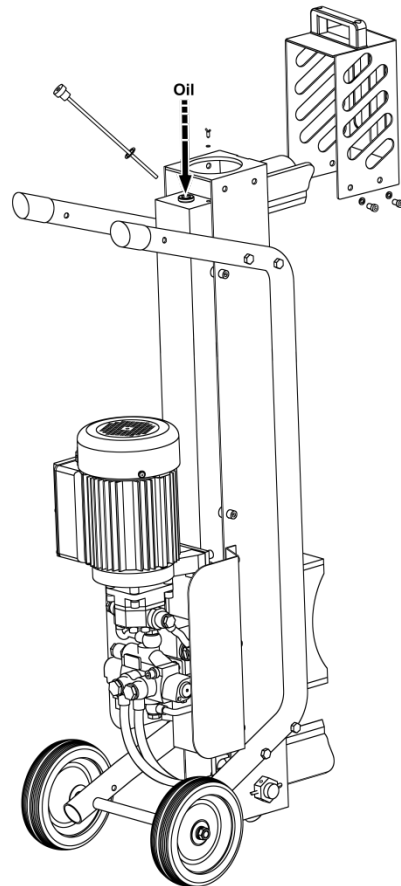

FIGURE 9.

Remove the safety shield and refill Oil to Desired Level



TROUBLESHOOTING

| Problem | Possible Cause | Solution |
|---|--|---|
| Motor fails to start. | <ul style="list-style-type: none"> • Overload Protection Device is disengaged to protect the log splitter from being damaged. | <ul style="list-style-type: none"> • Switch off the motor and unplug the power cable. Let motor cool down for half an hour and restart. If this does not solve the problem, call your dealer for customer support. |
| The log splitter won't split logs. | <ul style="list-style-type: none"> • Log is improperly positioned. • The size or hardness of the log exceeds the machine's capacity. • Wedge cutting edge is blunt. • Insufficient hydraulic oil. • Unauthorized adjustment was made on the Maximum Pressure Limiting Screw. Lower maximum pressure rating was set. | <ul style="list-style-type: none"> • Refer to <i>Operation</i> section for log loading. • Reduce the log size before splitting • Refer to "Sharpening The Wedge" in the <i>Maintenance</i> section. • Locate leak(s). Contact the dealer. • Contact the dealer. |
| Log ram jerks, vibrates or does not move. | <ul style="list-style-type: none"> • Unit is not placed on level ground. • Lack of hydraulic oil • Excessive air in the hydraulic system. • Log splitter is over forced. | <ul style="list-style-type: none"> • Reposition the log splitter to ensure that the wheel end of the unit is no higher than the other end. Check oil level for possible oil refilling. • Ensure vent plug is loose during operation • Turn off and restart the unit. • Contact the dealer. |
| Oil leaks from the hydraulic system or from other points. | <ul style="list-style-type: none"> • Air is sealed in hydraulic system while operating. • Vent plug is not tightened before moving the log splitter. • Oil drain bolt is not tight. • Hydraulic fitting(s) and/or seal(s) are worn. | <ul style="list-style-type: none"> • Loosen vent plug before operating the log splitter. • Tighten the vent plug before moving the log splitter. • Tighten the oil drain bolt. • Contact the dealer. |

TECHNICAL SPECIFICATIONS

| | |
|-------------------------|------------------------------------|
| Electrical requirements | 115V, 60Hz |
| Power output | 1500W |
| Rated current | 13.5A |
| Motor speed | 3400 RPM |
| Power cable | SJTW 14 AWG (2.08mm ²) |

| | | |
|---------------------------------|------------|--------------|
| Max splitting force | Extending | 8 ton |
| | Retracting | 7 ton |
| Max splitting length | | 20.5 in |
| Max splitting diameter | | 10.5 in |
| Hydraulic pressure | | 3400 PSI |
| Cylinder bore | | 2.5 in |
| Cycle time | Extending | 9 sec |
| | Retracting | 13 sec |
| Max cylinder stroke | | 18 in |
| Oil capacity | | 3 L |
| Machine dimensions (LxWxH) (in) | | 51.5x13.5x21 |
| Machine net weight | | 160 lbs |

EXPLODED DIAGRAM & PARTS LIST

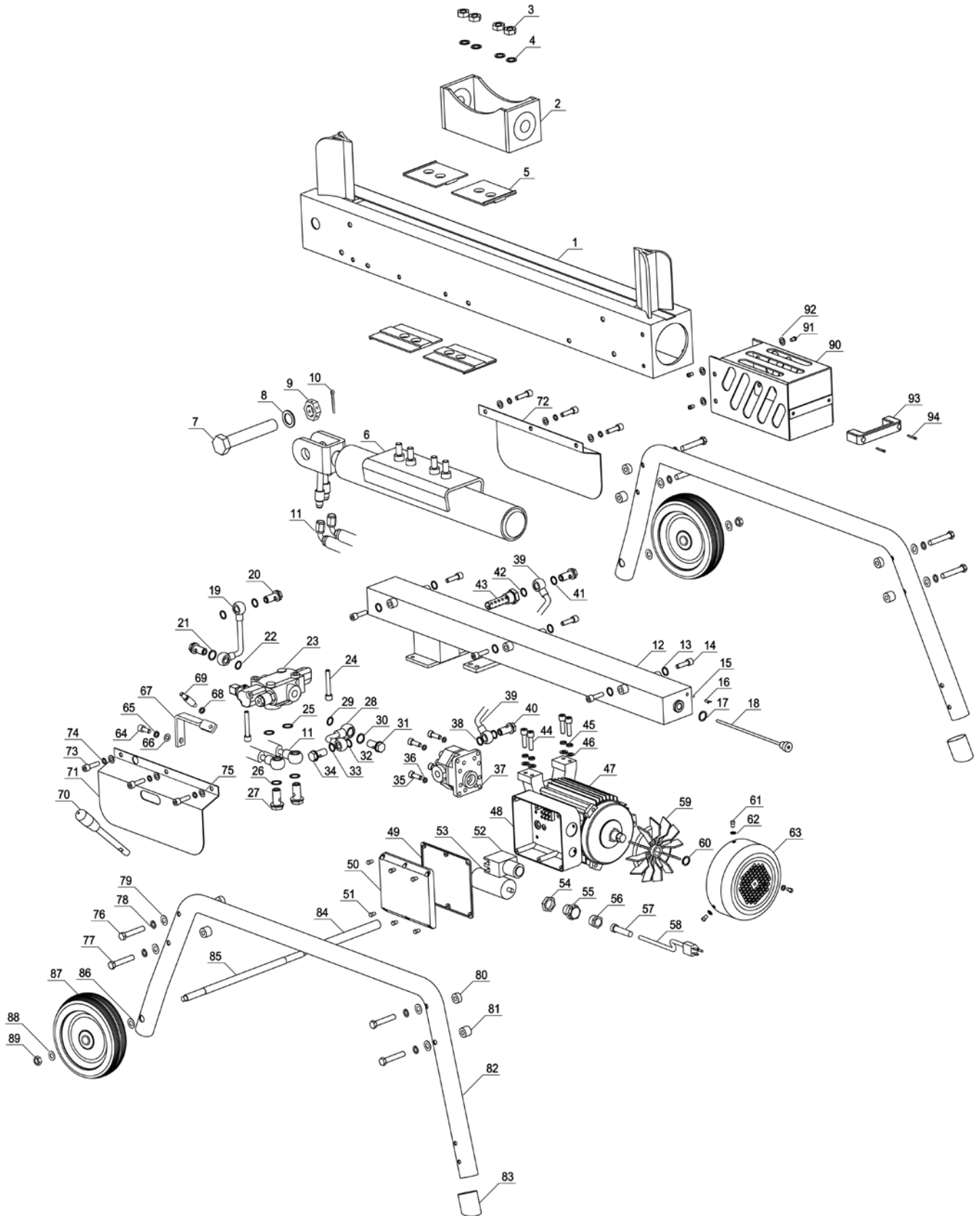

| REF # | PART # | PART NAME | SPECIFICATIONS | QTY PER SECTION |
|-------|---------|-----------------------------------|--------------------|-----------------|
| 1 | 310-874 | Machine Body Including End Wedges | | 1 |
| 2 | 530-447 | Ram | | 1 |
| 3 | 720-884 | Lock Nut | M14 | 4 |
| 4 | 750-300 | Flat Washer | M14*2 | 4 |
| 5 | 530-801 | Nylon Liner | | 4 |
| 6 | 530-493 | Hydraulic Cylinder | Ø63*571 | 1 |
| 7 | 710-191 | Bored Hex Head Bolt | M24*130 | 1 |
| 8 | 750-634 | Flat Washer | M24*4 | 1 |
| 9 | 720-845 | Bored Nut | M24 | 1 |
| 10 | 760-795 | Split Pin | Ø3*50 | 1 |
| 11 | 560-440 | Hydraulic Hose | Ø14-Ø19*245*4.5 | 2 |
| 12 | 540-973 | Reservoir | | 1 |
| 13 | 750-160 | Flat Washer | M8*1 | 6 |
| 14 | 710-084 | Inner Hex Head Bolt | M8*15 | 6 |
| 15 | 730-094 | O Seal Ring | Ø6*1 | 1 |
| 16 | 540-537 | Vent Plug | M4*10 | 1 |
| 17 | 750-158 | Copper Seal Washer | M14*1 | 1 |
| 18 | 540-276 | Oil Dipstick w/ Oil Drain Bolt | | 1 |
| 19 | 560-134 | Oil Return Tube | Ø16-Ø10*91*1 | 1 |
| 20 | 710-838 | Oil Tube Screw | M16*30 | 2 |
| 21 | 750-525 | Copper Seal Washer | M16*1 | 2 |
| 22 | 730-564 | O Seal Ring | Ø20*1.9 | 2 |
| 23 | 520-767 | Hydraulic Valve | | 1 |
| 24 | 710-991 | Inner Hex Head Bolt | M8*55 | 2 |
| 25 | 730-624 | O Seal Ring | Ø18*1.9 | 2 |
| 26 | 750-158 | Copper Seal Washer | M14*1 | 2 |
| 27 | 710-896 | Oil Tube Screw | M14*30*1 | 2 |
| 28 | 560-624 | Connecting Oil Tube | Ø16/Ø14-Ø10*69*1 | 1 |
| 29 | 730-564 | O Seal Ring | Ø20*1.9 | 1 |
| 30 | 750-525 | Copper Seal Washer | M16*1 | 1 |
| 31 | 710-838 | Oil Tube Screw | M16*30 | 1 |
| 32 | 730-624 | O Seal Ring | Ø18*1.9 | 1 |
| 33 | 750-158 | Copper Seal Washer | M14*1 | 1 |
| 34 | 710-896 | Oil Tube Screw | M14*30 | 1 |
| 35 | 710-895 | Inner Hex Head Bolt | M8*20 | 4 |
| 36 | 750-075 | Spring Washer | M8*2.3 | 4 |
| 37 | 550-203 | Hydraulic Pump | | 1 |
| 38 | 730-624 | O Seal Ring | Ø18*1.9 | 1 |
| 39 | 560-781 | Oil Suction Tube | Zinc, Ø14-Ø10*76*1 | 1 |
| 40 | 710-896 | Oil Tube Screw | M14*30 | 2 |
| 41 | 750-158 | Copper Seal Washer | M14*1 | 2 |
| 42 | 730-088 | O Seal Ring | Ø24*2.4 | 1 |
| 43 | 540-033 | Oil Filter | | 1 |
| 44 | 710-541 | Inner Hex Head Bolt | M8*35 | 4 |
| 45 | 750-075 | Spring Washer | M8*2.3 | 4 |
| 46 | 750-160 | Flat Washer | M8*1 | 4 |
| 47 | 910-234 | Electric Motor | | 1 |

| REF # | PART # | PART NAME | SPECIFICATIONS | QTY PER SECTION |
|-------|---------|-----------------------------------|----------------------------|-----------------|
| 48 | 920-011 | Connecting Box (Bottom) | | 1 |
| 49 | 920-506 | Connecting Box (Rubber Ring) | | 1 |
| 50 | 920-853 | Connecting Box (Cover) | | 1 |
| 51 | 740-603 | Cross Recess Pan Head Screw | M4*10 | 6 |
| 52 | 920-943 | Power Switch | | 1 |
| 53 | 920-980 | Capacitor | 60uf | 1 |
| 54 | 930-154 | Cable Fastener Nut | | 1 |
| 55 | 930-807 | Cable Fastener | | 1 |
| 56 | 930-233 | Cable Fastener Bolt | | 1 |
| 57 | 930-511 | Cable Bushing Rubber | | 1 |
| 58 | 930-182 | Power Cable | STJW 3/C 14AWG, Ø2.08*1600 | 1 |
| 59 | 910-194 | Fan | | 1 |
| 60 | 760-548 | Circlip for Shaft | Ø16 | 1 |
| 61 | 740-477 | Cross Recess Pan Head Screw | M4*10 | 3 |
| 62 | 750-270 | Flat Washer | M4*1 | 3 |
| 63 | 910-154 | Fan Cover | Ø162 | 1 |
| 64 | 710-895 | Inner Hex Head Bolt | M8*20 | 1 |
| 65 | 750-075 | Spring Washer | M8*2.3 | 1 |
| 66 | 750-160 | Flat Washer | M8*1 | 1 |
| 67 | 520-805 | L-Shape Connecting Plate | | 1 |
| 68 | 750-834 | Spring Washer | M8*2.3 | 1 |
| 69 | 520-682 | Control Handle Connecting Shaft | Ø12.5*56 | 1 |
| 70 | 520-002 | Control Handle Lever | Ø12.5*116 | 1 |
| 71 | 350-144 | Hydraulic System Shield Near Side | | 1 |
| 72 | 350-295 | Hydraulic System Shield Far Side | | 1 |
| 73 | 710-084 | Inner Hex Head Bolt | M8*15 | 6 |
| 74 | 750-075 | Spring Washer | M8*2.3 | 6 |
| 75 | 750-160 | Flat Washer | M8*1 | 6 |
| 76 | 710-690 | Hex Head Bolt | M8*55 | 4 |
| 77 | 710-654 | Hex Head Bolt | M8*60 | 4 |
| 78 | 750-834 | Spring Washer | M8*2.3 | 8 |
| 79 | 750-638 | Flat Washer | M8*1 | 8 |
| 80 | 750-519 | Flat Washer | Ø9*8.15 | 4 |
| 81 | 750-157 | Flat Washer | Ø9*15.5 | 4 |
| 82 | 320-921 | Joint Legs and Cradle | | 2 |
| 83 | 320-825 | Bumper | | 2 |
| 84 | 340-758 | Axle Bushing | Ø20*160 | 1 |
| 85 | 340-091 | Wheel Axle | Ø17*337 | 1 |
| 86 | 750-146 | Flat Washer | M13*2 | 2 |
| 87 | 330-214 | Wheel | 7**1.8' | 2 |
| 88 | 750-525 | Flat washer | M10*2 | 2 |
| 89 | 720-120 | Lock Nut | M10 | 2 |
| 90 | 350-779 | Safety Shield | | 1 |
| 91 | 710-879 | Inner Hex Head Bolt | M8*12*1 | 4 |
| 92 | 750-160 | Flat Washer | M8*1 | 4 |
| 93 | 320-511 | Towing Handle | | 1 |
| 94 | 740-313 | Cross Recess Pan Head Screw | M6*15 | 2 |

WARRANTY

LIMITED WARRANTY STATEMENT

Boss Industrial, Inc., ("Boss Industrial") warrants to the original retail purchaser that this BOSS brand outdoor product is free from defect in material and workmanship and agrees to repair or replace, at Boss Industrial's, discretion, any defective product free of charge within these time periods from the date of purchase.

- Two years for all models if used for personal, family, or household use;
- 90 days for any unit used for other purposes, such as rental or commercial.

This warranty extends to the original retail purchaser only and commences on the date of the original retail purchase.

Any part of the this product manufactured or supplied by Boss Industrial and found in the reasonable judgment of Boss Industrial to be defective in material or workmanship will be repaired or replaced without charge for parts and labor by a Boss Industrial authorized service center.

The product, including any defective part, must be returned to an authorized service dealer within the warranty period. The expense of delivering the product to the dealer for warranty work and the expense of returning it back to the owner after repair or replacement will be paid by the owner. Boss Industrial's responsibility in respect to claims is limited to making the required repairs or replacements and no claim of breach of warranty shall be cause for cancellation or rescission of the contract of sale of any BOSS brand product. Proof of purchase will be required by the dealer to substantiate any warranty claim. All warranty work must be performed by a Boss Industrial authorized service center.

This warranty is limited to ninety (90) days from the date of original retail purchase for any Boss Industrial brand product that is used for rental or commercial purposes, or any other income-producing purpose.

This warranty does not cover any BOSS brand product that has been subject to misuse, neglect, negligence, or accident, or that has been operated in any way contrary to the operating instructions as specified in this operator's manual. This warranty does not apply to any damage to the product that is the result of improper maintenance or to any product that has been altered or modified. The warranty does not extend to repairs made necessary by normal wear or by the use of parts or accessories which are either incompatible with the BOSS brand product or adversely affect its operation, performance, or durability. In addition, this warranty does not cover:

B. Tune-ups – Spark Plugs, Carburetors
Adjustments, Ignition, Filters

B. Wear items – Bump Knobs, Outer Spools, Cutting Lines, Inner Reels, Starter Pulleys, Starter Ropes, Drive Belts, Tines, Felt Washers, Hitch Pins, Mulching Blades, Blower Fans, Blower and Vacuum Tubes, Vacuum Bags and Straps, Guide Bars, Saw Chains

Boss Industrial reserves the right to change or improve the design of any BOSS brand product without assuming any obligation to modify any product previously manufactured.

ALL IMPLIED WARRANTIES ARE LIMITED IN DURATION TO THE STATED WARRANTY PERIOD. ACCORDINGLY, ANY SUCH IMPLIED WARRANTIES INCLUDING MERCHANTABILITY, FITNESS FOR A PARTICULAR PURPOSE, OR OTHERWISE, ARE DISCLAIMED IN THEIR ENTIRETY AFTER THE EXPIRATION OF THE APPROPRIATE TWO-YEAR, ONE-YEAR, OR NINETY-DAY WARRANTY PERIOD. BOSS INDUSTRIAL'S OBLIGATION UNDER THIS WARRANTY IS STRICTLY AND EXCLUSIVELY LIMITED TO THE REPAIR OR REPLACEMENT OF DEFECTIVE PARTS AND BOSS INDUSTRIAL DOES NOT ASSUME OR AUTHORIZE ANYONE TO ASSUME FOR THEM ANY OTHER OBLIGATION. SOME STATES DO NOT ALLOW LIMITATIONS ON HOW LONG AN IMPLIED WARRANTY LASTS, SO THE ABOVE LIMITATION MAY NOT APPLY TO YOU. BOSS INDUSTRIAL ASSUMES NO RESPONSIBILITY FOR INCIDENTAL, CONSEQUENTIAL, OR OTHER DAMAGES INCLUDING, BUT NOT LIMITED TO, EXPENSE OF RETURNING THE PRODUCT TO AN AUTHORIZED BOSS INDUSTRIAL SERVICE CENTER AND EXPENSE OF DELIVERING IT BACK TO THE OWNER, MECHANIC'S TRAVEL TIME, TELEPHONE OR TELEGRAM CHARGES, RENTAL OF A LIKE PRODUCT DURING THE TIME WARRANTY SERVICE IS BEING PERFORMED, TRAVEL, LOSS OR DAMAGE TO PERSONAL PROPERTY, LOSS OF REVENUE, LOSS OF USE OF THE PRODUCT, LOSS OF TIME, OR INCONVENIENCE. SOME STATES DO NOT ALLOW THE EXCLUSION OR LIMITATION OF INCIDENTAL OR CONSEQUENTIAL DAMAGES, SO THE ABOVE LIMITATION OR EXCLUSION MAY NOT APPLY TO YOU.

This warranty gives you specific legal rights, and you may also have other rights which vary from state to state.

This warranty applies to all BOSS brand products manufactured by or for Boss Industrial and sold in the United States and Canada.

PACKING LIST

(1) Log Splitter

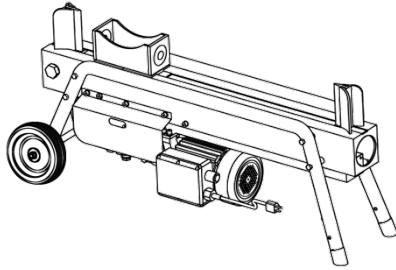

(1) Safety Shield

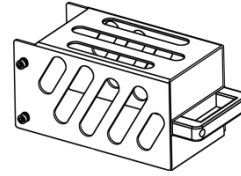

(1) Control Lever

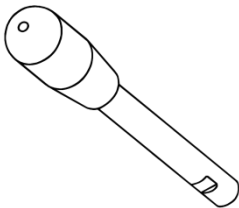

(1) Operator's Manual



(1) Hex Wrench

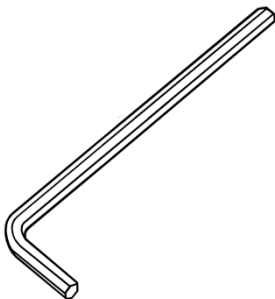



Boss Industrial, Inc. • 1864 High Grove Lane, Unit 116 • Naperville, IL 60540 •
USA

Phone: (800) 780-BOSS (2677) • Fax (331) 472-2976

www.boss-industrial.com