

POWER KING[®]

4 INCH Quad Cycle Chipper Shredder

PK0903 POWERKING Manual



Read through this owner's manual carefully before using product, to insure the safety of yourself and others.

Due to continuing improvements, actual product may differ slightly from the product described herein.

Contents

I . Safety instructions-----	3
II . Technical parameter-----	4
III. Structural character-----	5
IV. Working process-----	5
V . Operating instructions and warnings-----	5
VI. Maintenance instructions-----	6
VII. Installation instructions-----	7
VIII. Transport and storage-----	7
IX. Attachment-----	7
X. Trouble shooting-----	13

I . Safety instructions



1.The machine must not be used in any other way than described in the manual.



2.Use only original equipment and spare parts. If you use non-approved spare parts, there is increased risk and this is, therefore, not permissible. All liability is renounced in the event of an accident or other damage caused by the use of non-approved parts.



3.Before using the machine for the first time, read and follow this manual.



4.When using the machine you are responsible for any third party in the area where the machine is in operation. Never use the machine in the presence of others, especially children or animals.



5.Do not allow minors to operate the machine.



6.The machine may only be lent to mechanics who are familiar with operating the machine. Always keep the safety and operational instructions attached with the machine.



7.Do not remove or add other parts after finishing installing the machine at the factory, e.g. removing the belt guard.



8.Check all the safety parts in their proper positions and remember to tighten all bolts and nuts before starting the machine.



9.Choose a flat work place. Machine can only used in the outdoors or in the well ventilated case. Away from flammable and explosive object. Avoid buns, fall, fire, explosion and other safety incident.



10.When working with the machine wear close-fitting work clothes, sturdy work gloves, eye protector, ear muff, dustproof mask and antiskid shoes .



11.Before and after using the machine, proper maintenance is necessary. This could avoid some security incidents, and extend the life of the machine.



12.Before using the machine, please read the carefully the instructions and understand well .

Failure to comply with instructions could result in personal injury and/or damage to product or property.

13. Safety labeling and significance



Read the instructions carefully before operating.



DANGER, pay attention to safety.



Keep hands away from the rolling parts.



Beware of cutting the fingers.



Keep a safe distance from the working machine.



Beware of objects thrown out of the machines.

II. Technical parameter

Model: PK0903

Max. Chipping Capacity: 4inches DIA

Chipping Fineness: Granulated Detrital

Function: Chipping leaves, branches, crop straw and farming feed, etc.

Max. Blade Speed: 2530r/min

Engine Type: OHV4-stroke

Engine: Kohler CH395

Displacement: 277cc

Max Output: 9.5HP/3600rpm

Starting System: Recoil

Fuel Type: 93# clean Unleaded Gasoline

Efficacy: 800-4000kg/h

Principal axis rotation direction: anticlockwise

Carton Size: 114Cm×66Cm×112Cm

Attachment: Users manual and toolkit



WARNING: This product can expose you to chemicals including benzene, carbon monoxide, and lead which is known to the State of California to cause cancer and birth defects or other reproductive harm. For more information go to www.P65Warnings.ca.gov.

III. Structural character

This series of high efficient machine has safe protection, firm structure, steady operation. Fuselage are all made of high quality steel, blades are made of high speed steel HSS, sharp cutting edge have good toughness, hardness, impact resistance and anti-abrasive.

The machine are consist of frame1, feed hopper9, outlet hopper 10, wheel2, support frame 4 (details please find in attachment). The crush room, transmission device and power device are fixed in fuselage1.

IV. Working process

There are hopper and discharge port on the machine, drawing materials in hopper when it is in operation, the materials through hopper to get into inner crusher room. Due to the blades of cutter wheel in inner crusher room are made a relative movement in high speed and cut the materials during the movement. After cutting, materials are discharged through the discharge port.

V. Operating instructions and warnings

Please read carefully and understand the engine instruction manual before using. The engine shipped from factory without lubricant and fuel.

Do not drink ; take drugs or narcotic drugs before starting the machine.

Take some protective measures before starting the machine.

It is necessary to have an empty running test to make sure linking parts are firm enough, and check the amount of oil and fuel before operation. Turn on the motor to have an empty running test. (Detail information please find in the motor manual instruction.) After testing, it can be had a test with load from slight to heavy. Do not operate machine with overload, the raw material put the feeding hopper should be too big .it is determined by motor load. If it is overload, immediately reduce or stop to draw the materials in. After a period of regular movement, putting into production under no unusual noise or overheat phenomenon.

Keep the minors away from the spot.

Do not put hands or other body parts into hopper.

Do not get close to discharge port, the chips are expelled from discharge port can hurt you or may cause serious injury.

If the machine makes abnormal vibration or unusual noises, immediately turn the machine off and check it.

If there are many uncut materials, blades may be needed to sharpen or intervals are needed to make adjustment. It is easy to cause injury due to blades are sharp enough. Sharpen or adjust blades should go to indicate maintenance point. The recommendation of blade intervals is 1-2mm.

Choice of chipping material: the fresh cut trees branches and straws can be chipped directly. Due to different hardness and moisture content, the engine may stop midway or the machine body may shake during the working, that's normal. Our recommend max. chipping capacity point to the annual plant, such as trees, and straws. If chipping the perennial plant, you should shorten the chipping diameter and lessen the material to feeding hopper . The ideal chipping for this machine is suitable for fresh cut with 80% moisture content plant. During the chipping process, you should obey the rule: Big side first, small side later, the trunk first, the branch later. In order to get good chipping, it's better put branches and leaves together with the the bulk or segment of big trees. Block and short materials are not allowed to be chipped separately, for the safety of the operator and the good of the blades, they are better to be crushed with branches or straw.

VI. Maintenance instructions

This series of machine is only the main shaft bearing, which is needed to infuse lubricating oil. After a period of using, it is necessary to infuse the grease. How often to infuse grease is determined by using environment and it's frequency. You must

infuse the grease after using 50 hours because the lack of grease can easily cause bearing damage. Check all the parts regularly with 1-2 times monthly including bearing, blades, belt etc. Make sure they are flexible and sharp. Replace the blades as soon as the chipping performance begins to deteriorate. The blades are needed to check regularly. The blunt blades will lower working efficiency and cause the damage of machine.

Protection and maintenance of machine should carry out in accordance with the engine manual construction.

VII. Installation instructions

Packing is after the dismantling of the machine, remove parts from the packing box after the dismantling of the machine. According to attachment can make a simple assembly for use. Remember: the bulk and weight of partial components are large; you should get help to assemble the machine in order to ensure the safety. (This schematic is only used for simple installation, but not for technical or other uses.

VIII. Transport and storage

Turn off the engine before moving the machine, and turn off the fuel controls to maintain its lever in order to prevent overflowing the fuel, or it may cause the fire.

If you need to store the machine for a long time, please note the following points:

1. Please choose the place of good ventilated and clearance, and make sure that without adults can not be ran or used.
2. Please discharge gasoline into proper fuel tank, and safe keeping of it.
3. Do maintenance and deal with the rust-proof treatment.

IX. Attachment

Pic1. Frame installation(PK0903 series)

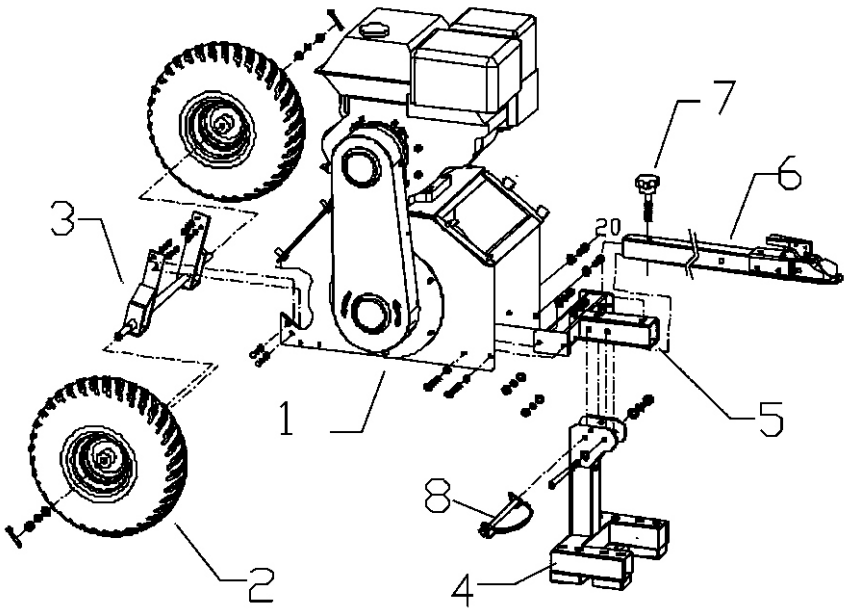

Serial Number	1	2	3	4	5	6	7	8
description	frame	wheel	axle stand	support frame	joint pipe	tow bar	knob	D-pin

Installation procedure: first, lay the frame 1 on a elongated support or platform that is about 30cm high from the ground, and leave some space at the sides of the frame for the installing of the wheel2 and support frame 4, as it is showed in the pic, fix wheel2 with suitable fasteners to axle stand3, then fix the finished structure to frame1. Install joint pipe5 to the corresponding position on the frame, and then connect and fix support frame 4 and joint pipe5&D-pin,and mount tow bar6 and knob7.After the installation is complete, the elongated support or platform can be removed and step into next phase.



In the process of installation, do not place hands or any other body parts within a radius of cutter wheel rotary. Do not touch the blades with your hands or any other body parts. Considering the heavy weight of the machine, pls do not try to install it by oneself in case of the possible injury.

Pic2. Feed Hopper and Out let Hopper Installation

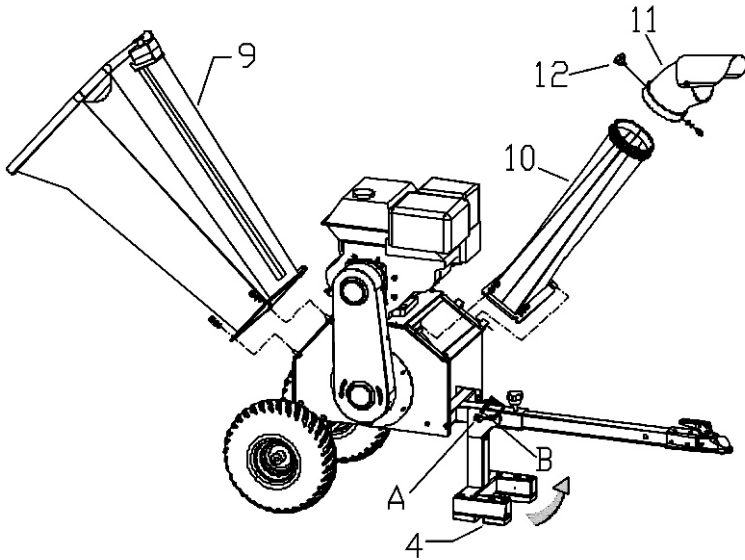

Serial No.	9	10	11	12
description	feed hopper	lower part of outlet hopper	Upper part of outlet hopper	knob

1. Connect the hinger of lower part of outlet hopper 10 to the one on the frame with screw nut, then put the upper part 11 on the lower part 10 with bolts and knob 12.

2. Connect the hinger of feed hopper 9 to the one on the frame with screw nut.

If support feet 4 needs to be folded, pull D-pin out (at the A area) to the hole (at the B area)



In the process of installation, do not place hands or any other body parts within a radius of cutter wheel rotary. Do not touch the blades with your hands or any other body parts. Regarding the heavy weight of the machine, pls do not try to install it by oneself in case of the possible injury.

X. Troubleshooting

The common faults		Elimination method
1	The engine cannot be started	Read the engine users' manual, check the fuel ON-OFF, see if it's ON, check if gets enough fuel and lubrication oil, check the emergency stop button.
2	Engine flameout midway	Check if the engine is stopped by overloading, check if something blocked in the chipping hopper, check the emergency stop button and protection switch.
3	The hopper blocked	Stop the machine, and remove the hoppers and the cap of bearing, turn the shaft of roller by the right spanner in the toolkit to clear the blocked material. Don't touch the blade during the working, make sure your hands not to be cut by the blades.
4	Has strange noise	Stop the machine, check if the fastener gets loose, if not, let the professionals to check the repair.
5	The blade destroyed	Go to the professional repair point to change or repair the blades.
6	The belt damage	Open the belt cover and change the belt.
7	The material grinding not sufficient	Let the professional to adjust the blade space, the recommended space for rough chipping is 1.5mm-3mm, for fine chipping is 0.1mm-1.2mm.

WARRANTY POLICY

Thank you for choosing QV TOOLS Products. We're here to ensure that your experience is perfect. In some rare instances, you may need some help with a warranty claim.

Please call us at 1-800-344-3371.

Product must be registered to activate the warranty. Warranty registration is below. Warranty begins from date of purchase.

Engine Warranty

Kohler engines are covered with a 3-year commercial and 3-year residential warranty for Command Pro series. Parts and Labor are covered as well. Power King engines by Lifan are covered with a 1-year residential warranty. QV Power 3pt 40hp gear box warranty 1-year. Visit your engine manufacturer for warranty details or visit **www.QVTools.com**.

Equipment warranty

Manufactures defects of chassis and component parts are covered for 1 year. Only parts are covered. Shipping cost is not covered.

QV Tools will replace any part that is proven to be defective in material or workmanship. This warranty is not valid for products or parts affected or damaged by accident, collision, normal wear, fuel contamination, abuse, neglect, misuse, alteration and/or unsuitable use or unauthorized parts. Transportation charges to and from service centers, if assigned, is not covered. Shipping cost of product for repair is not covered. Labor to repair equipment is not covered. Consumable parts such as brake pads, tires, racks, splines, grinding teeth, blades, bar blades, etc. are not covered under warranty. Power King has all replacement parts at value pricing.

Damaged Products

You must take the time to inspect the goods before you sign the delivery receipt from the carrier. If you sign the delivery receipt without inspecting the shipment, you will be responsible for filing a freight claim and arranging for a repair or return of the damaged goods.

Concealed damage claims must be reported immediately.

Suspected Damage

On occasion, the outer carton may look damaged, but the product inside the box is perfectly fine. If you suspect concealed damage, notate "**Possible Freight Damage**" on the **delivery receipt while the driver is present. This way, if you discover later that the product is damaged, the remedy of a freight claim is less of a hassle.**

Obvious Damage

Do not sign for damaged products. If your product arrives damaged, **please (a) REFUSE DELIVERY and (b) Call where you purchased the item Immediately so the dealer can process the appropriate claims and coordinate an exchange for you.**

Defective Products

We encourage you to test your product within 15 days of receipt so we can quickly remedy any mechanical problems. If you think your product is defective, **call QVTools at 1-800-344-3371**. In most cases, it's a simple issue that can be resolved over the phone. We have expert technicians standing by to help resolve your issue. Please have your model number and serial number available and your proof of purchase receipt for faster service.

Original Owner Warranty

Warranty is non-transferable and covers the original owner only who purchased from a QVTOOLS authorized dealer.